

03V/VA
C3V/VA

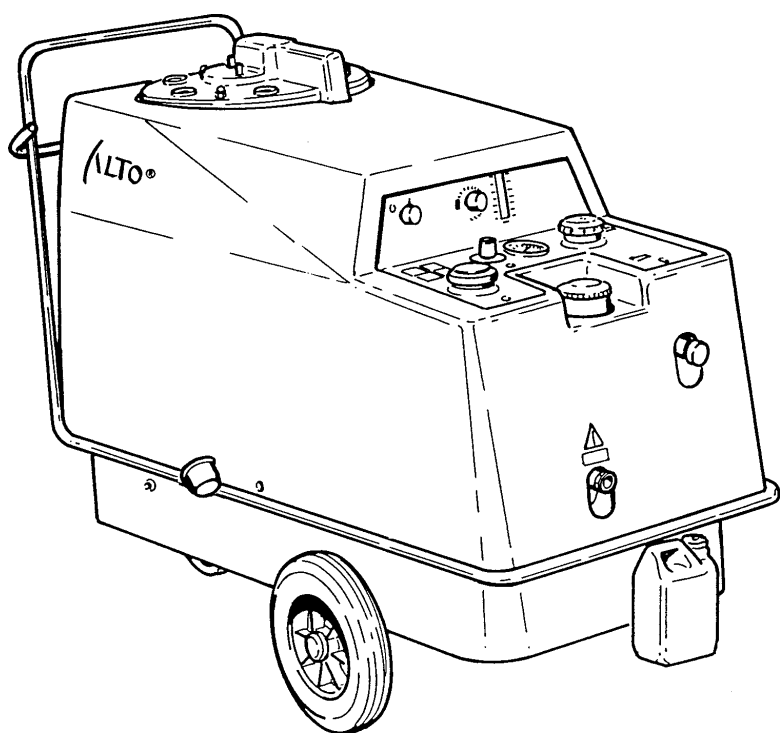

ALTO®

Total Cleaning
Confidence™

Reserve de le
Spare parts
Ersatzteile
Pièces détachées

598 73 99 - 00.08

3 INDEX
5

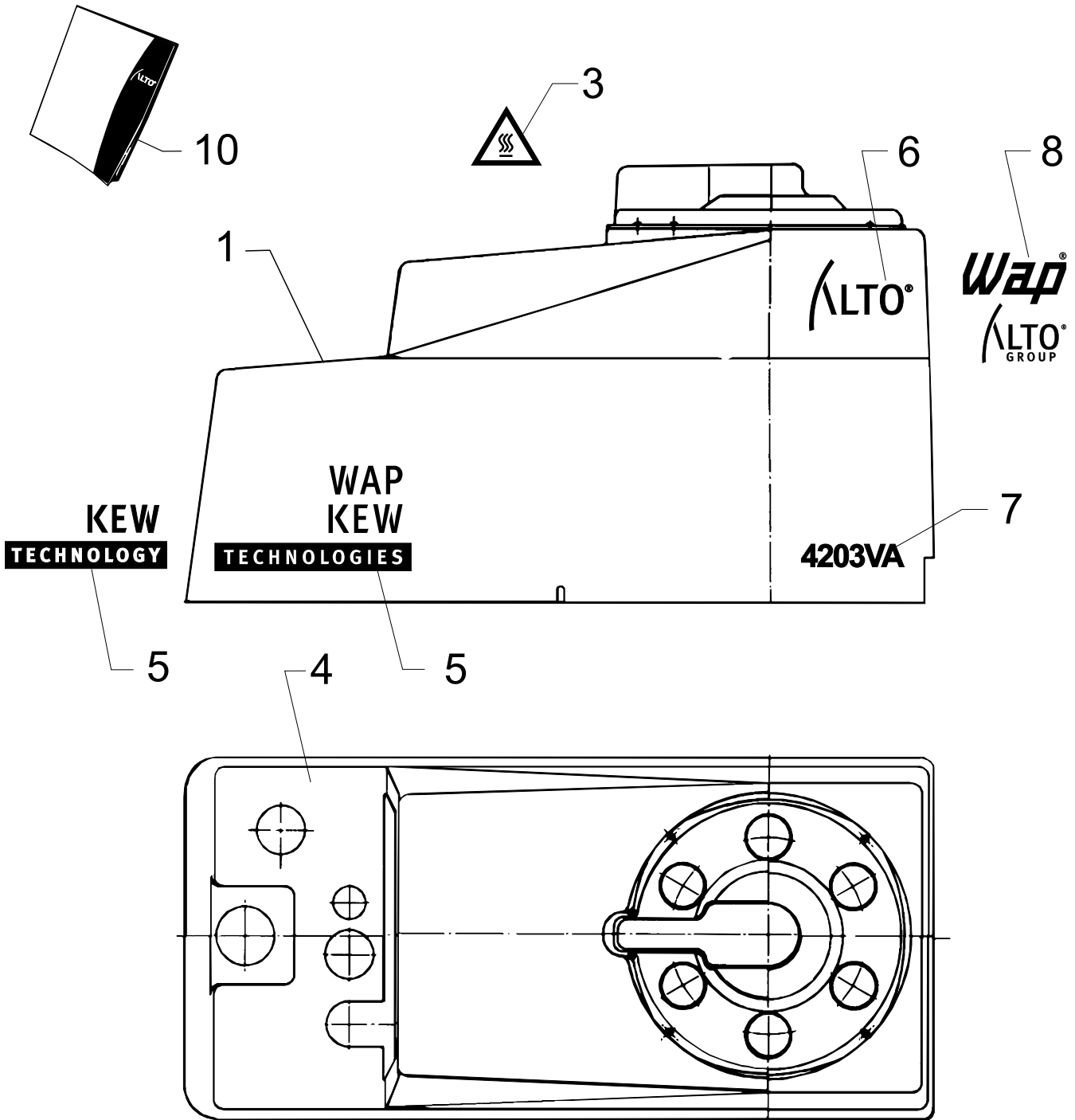

Pos. Ref.	Nr. No.	Betegnelse Bezeichnung	Designation Désignation	3803	4203/C3	5003/C3
-	-	Kabinet, kompl. Cabinet, compl. Haube, kompl. Capot, compl.		x	x	x
1	6226112	Kabinet, ALTO Cabinet Haube Capot		1	1	1
3	4210066	Advarselslabel "varmeoverførsel" Warning label "heat transfer" Warnaufkleber "Wärmeübertragung" Avertissement "transmission chaaleur"		1	1	1
4	6220159	Label for instrument panel Label for control panel Aufkleber für Armaturenbrett Autocollant p. tableau de commande		1	1	1
-	6200144	Advarselsskilt f. brændstof Warning sign f. fuel Warnschild f. Brennstoff Plaque d'avertissement p. fuel				
5	6201141	KEW TECHNOLOGY logo KEW TECHNOLOGY logo KEW TECHNOLOGY logo KEW TECHNOLOGY logo		2	2	2
5	6226129	WAP KEW TECHNOLOGIES logo WAP KEW TECHNOLOGIES logo WAP KEW TECHNOLOGIES logo WAP KEW TECHNOLOGIES logo		2	2	2
6	6226125	ALTO logo ALTO logo ALTO logo ALTO logo		2	2	2
7	-	Logo, ALTO Logo Logo Logo				
-	6226121 6226120 6226119	3803V 4203V 5003V		2	2	2
-	6226118 6226117 6226116	3803VA 4203VA 5003VA		2	2	2
-	6226122 6226115 6226114	42C3V 42C3VA 50C3VA			2	2
8	6226128	Wap ALTO GROUP logo Wap ALTO GROUP logo Wap ALTO GROUP logo Wap ALTO GROUP logo		2	2	2
-	-	Advarselsskilt Warning sign Warnschild Plaque de bord				
-	4205514 4205423 4205431 4206132	DK GB, I D, A, CH A				
-	4205449 4206074 4200457 6101055	NL, F, B SF SF SF				

Pos. Ref.	Nr. No.	Betegnelse Bezeichnung	Designation Désignation	3803	4203/C3	5003/C3
10	-	Instruktionsbøger Instruction manuals Betriebsanleitungen Livrets d'instructions	Wap KEW TECHNOLOGIES			
-	6229046	DK, N, S, FIN				
-	6229047	GB, D, F, NL, E, I, P, GR				
-	6229048	US, (GB)				
-	6229049	CDN, (GB, F)				
10	-	Instruktionsbøger Instruction manuals Betriebsanleitungen Livrets d'instructions	Wap ALTO GROUP			
-	6229050	GB, D, F, NL, E, I, P, GR				
-	7189014	Tillæg / appendix / Anhang / Annexe				

Stel / Chassis / Rahmen / Châssis

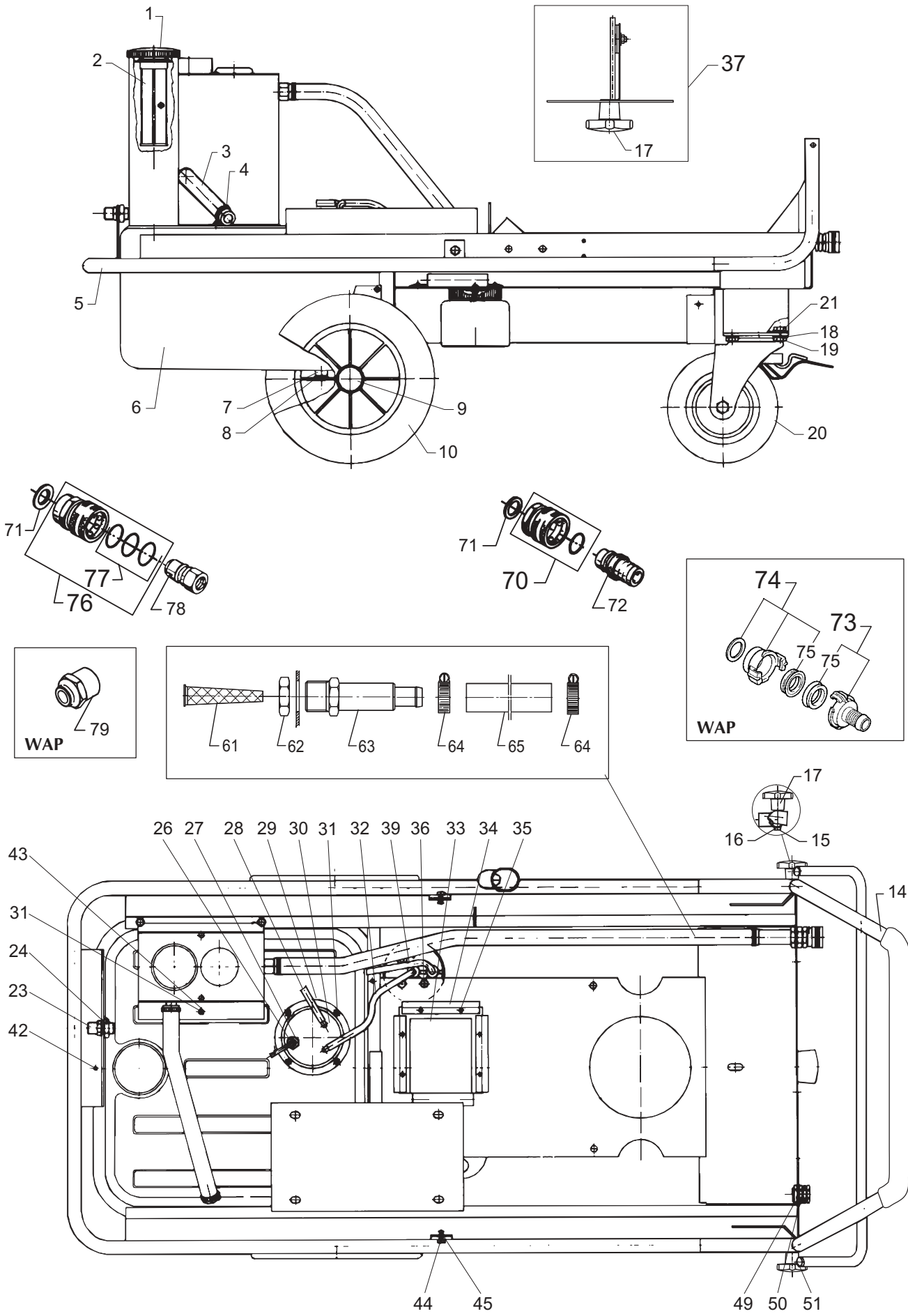

Pos. Ref.	Nr. No.	Betegnels Bezeichnung	Designation Désignation	3803	4203/CS	5003/CS
-	-	Stel, monteret Chassis, mount. Rahmen, montiert Châssis, monté		x	x	x
1	2011104	Låg f. brændstof Cover f. fuel tank Deckel f. Brennstofftank Couvercle du réservoir fuel		1	1	1
2	1604222	Påfyldningssi Fuel filling (filter) Brennstoffauffüllung (Filter) Filtre		1	1	1
3	6220477	Slange Hose Schlauch Flexible		1	1	1
4	1802107	Spændebånd Hose clip Schlauchschelle Collier de serrage		2	2	2
5	6220200	Stel Chassis Rahmen Châssis		1	1	1
6	6220202	Brændstofftank Fuel tank Brennstofftank Réservoir à fuel		1	1	1
7	3001468	Fiberskive Fibre washer Fiberscheibe Rondelle		1	1	1
8	6200529	Aftapningsskrue Drain screw Ablaßschraube Vis de vidange fuel		1	1	1
9	2004265	Navkapsel Hub cap Nabenkappe Enjoliveur		2	2	2
10	2011146	Hjul Wheel Rad Roue		2	2	2
14	6224229	Bagbøjle Clamp rear Bügel, Hinten Collier, arrière		1	1	1
15	4600559	Dupsko Ferrule Zwinge Fer		4	4	4
16	6100123	Skrue Screw Schraube Vis		2	2	2
17	4000279	Stjernegreb Star handle Sterngriff Poignée en étoile		3	3	3
18	1801968	Stjerneskrive Washer Scheibe Rondelle		4	4	4
19	1800465	Møtrik Nut M4 Mutter Ecrou		4	4	4
20	2005619	Drejehjul Steerable wheel Lenkrad Roue pivotante		1	1	1
21	1802305	Skrue Screw Schraube Vis		4	4	4
23	6200484	Forskruning Threaded connection Verschraubung Raccord fileté		1	1	1

Pos. Ref.	Nr. No.	Betegnels Bezeichnung	Designation Désignation	3803	4203/CS	5003/CS
24	1803220	Kontramøtrik Lock nut Gegenmutter Contre écrou		1	1	1
26	1801026	Kontramøtrik Lock nut Gegenmutter Contre écrou		1	1	1
27	3000429	Fiberskive Fibre washer Fiberscheibe Rondelle		1	1	1
28	6200479	Olieslange Hose (fuel) Schlauch (Brennstoff) Durite à fuel		1	1	1
29	6240091	Pakning Gasket Dichtung Joint		1	1	1
30	6220212	Dæksel Cover Deckel Couvercle		1	1	1
31	1802743	Møtrik Nut Mutter Ecrou		5	5	5
32	6200481	Olieslange Hose (fuel) Schlauch (Brennstoff) Durite à fuel		1	1	1
33	6220070	Pakning f. blæser Gasket f. fan Dichtung f. Gebläse Joint p. ventilateur		1	1	1
34	6220069	Holder f. pakning Holder f. gasket Halterung f. Dichtung Support du joint		3	3	3
35	1803618	Popnitte Rivet Niet Rivet		6	6	6
36	1810167	Skrue Screw Schraube Vis		2	2	2
37	6202222	Spjældplade, kompl. Plate f. throttle, compl. Platte f. Luftschieber, kompl. Plaquette du régulateur, compl.		1	1	1
39	6200477	Olieslange Hose (fuel) Schlauch (Brennstoff) Durite à fuel		1	1	1
42	1803592	Pladeskrue Plate metal screw Blechschrabe Vis		7	7	7
43	1804152	Skive Washer Scheibe Rondelle		1	1	1
44	6200145	Skrue Screw Schraube Vis		2	2	2
45	1803832	Seegerring Seeger circlip ring Seegerring Anneau Seger		2	2	2
49	3800786	Kontramøtrik Lock nut Gegenmutter Contre-écrou		1	1	1
50	3800760	Trækafastning Cable lead- in Zugentlastung Passe fil		1	1	1

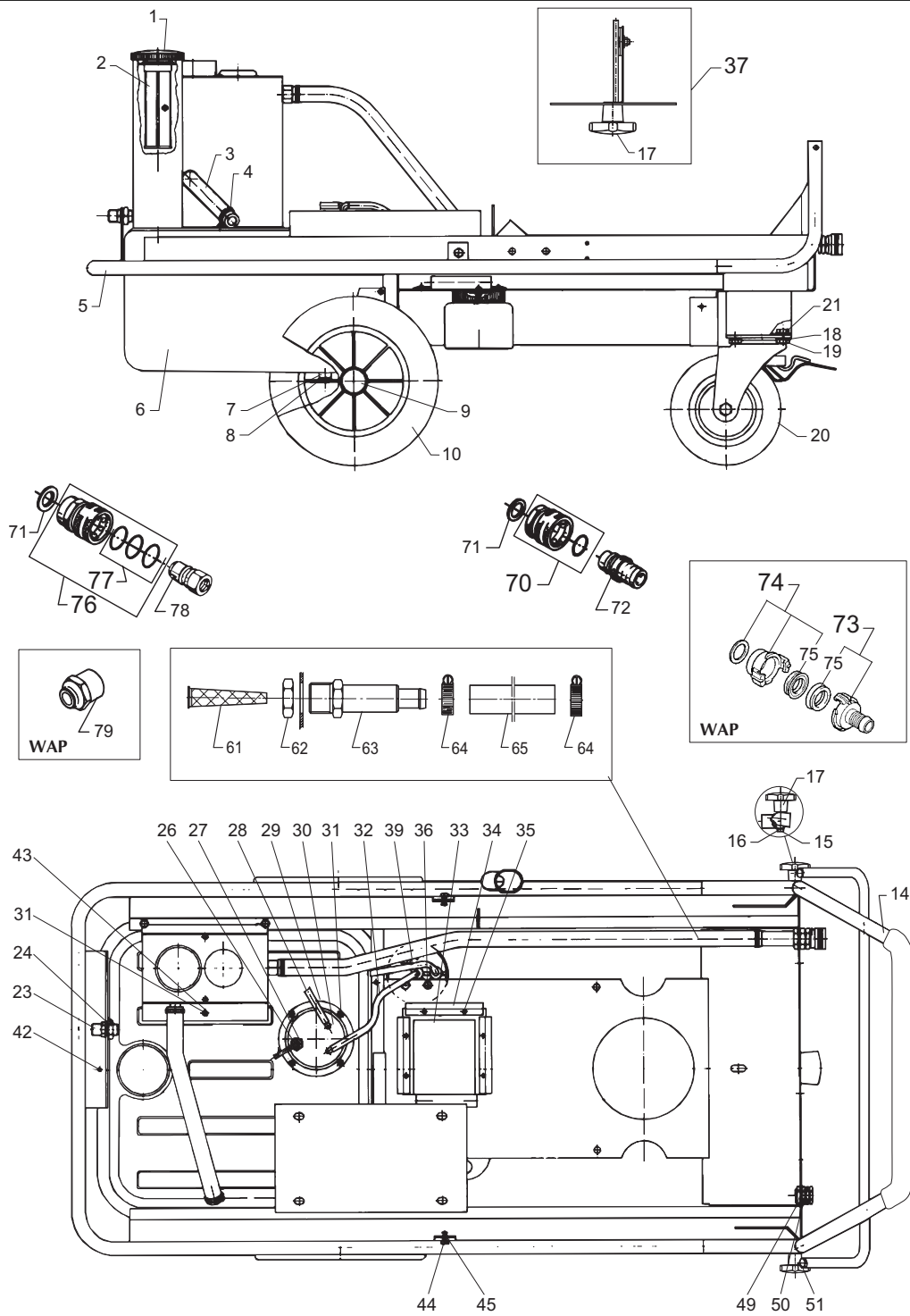

80

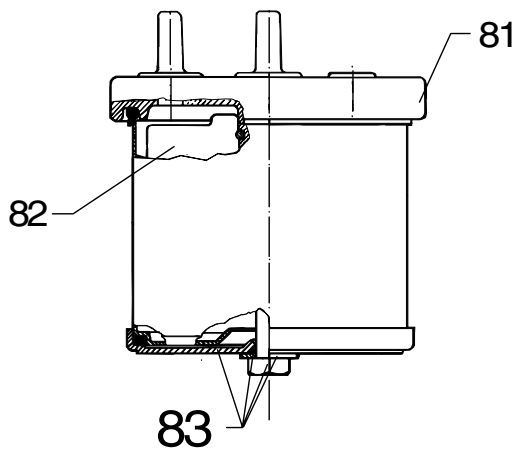

90

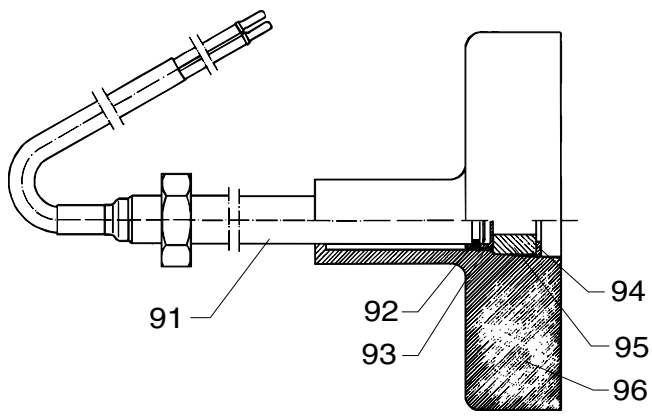

Pos. Ref.	Nr. No.	Betegnels Bezeichnung	Designation Désignation	3803	4203/C3	5003/C3
51	4600490	Dupsko Ferrule Zwinge Embout		2	2	2
60	-	Vandtilslutning, kompl. Water inlet, compl. Wasseranschluß, kompl. Admission eau, compl.		x	x	x
61	6100941	Filter Filter Filter Filtre		1	1	1
62	1800341	Kontramøtrik Lock nut Gegenmutter Contre écrou		1	1	1
63	6100937	Filterhus Filter housing Gehäuse f. Filter Carter filtre		1	1	1
-	6101094	Filterhus, messing Filter housing, brass Gehäuse f. Filter, Messing Carter filtre, laiton		1	1	1
64	1802107	Spændebånd Clip Schelle Collier de serrage		2	2	2
65	6220478	Slange Hose Schlauch Flexible		1	1	1
70	1602945	Lynkobling, kompl. (lavtryk) Quick coupling, compl. (l.p.) Schnellkupplung, kompl. (N.D.) Coupleur rapide, compl. (b.p.)		1	1	1
71	1801075	Tætningsskive Sealing washer Dichtungsscheibe Rondelle d'étanchéité		2	2	2
72	1600659	Lynkoblingsnippel (lavtryk) Nipple f. quick coupling (l.p.) Nippel f. Schnellkupplung (N.D.) Entrée du coupleur rapide (b.p.)		1	1	1
-	1605955	Lynkoblingsnippel (lavtryk) Nipple f. quick coupling (l.p.) Nippel f. Schnellkupplung (N.D.) Entrée du coupleur rapide (b.p.)	USA			
-	1602473	Lynkoblingsnippel (lavtryk) Nipple f. quick coupling (l.p.) Nippel f. Schnellkupplung (N.D.) Entrée du coupleur rapide (b.p.)	5/8"			
73	1311	Geka koblingsnippel 3/4" Geka-coupling nipple 3/4" Geka-Schlauchtülle 3/4" Coupleur mâle Geka 3/4"	WAP	1	1	1
74	1718	Geka kopling 3/4" Geka-threaded piece 3/4" Geka-Gewindestück 3/4" Coupleur Geka 3/4"	WAP	1	1	1
75	6502	Pakning for Geka kobling Packing for Geka coupling Dichtung für Geka-Kupplung Joint pour coupleur Geka	WAP	2	2	2
76	1402890	Lynkobling, kompl. (damp) Quick coupling, compl. (steam) Schnellkupplung, kompl. (Dampf) Coupleur rapide, compl. (vapeur)		1	1	1
77	1118132	Rep. sæt, pakning + O-ring Rep. kit, gasket + O-ring Rep. satz, Dichtung + O-Ring Kit de rép., joint + joint torique		1	1	1
78	1600493	Lynkoblingsnippel (højtryk) Nipple f. quick coupling (h.p.) Nippel f. Schnellkupplung (H.D.) Entrée du coupleur rapide (h.d.)		1	1	1
-	1603101	Lynkoblingsnippel, RF (højtryk) Nipple f. quick coupling, SS H.P. Nippel f. Schnellkupplung, RF H.D. Entrée du coupleur rapide, INOX H.P.		1	1	1

Pos. Ref.	Nr. No.	Betegnels Bezeichnung	Designation Désignation	3803	4203/C3	5003/C3
79	64235	Konverter (højtryk) Converter (high pressure) Konverter (Hochdruck) Convertisseur (haute pression)	WAP	1	1	1
80	6200466	Oliefilter, komplet Fuel filter, complete Brennstofffilter, komplett Filtre à fuel, compl.		x	x	x
81	6200445	Filterdæksel Filter cap Deckel für Filter Couvercle du filtre		1	1	1
82	1604248	Oliefilter Fuel filter Brennstofffilter Filtre à fuel		1	1	1
83	1119301	Rep.sæt, filter bund Rep.kit, bottom sect. f. filter housing Satz, Unterer Teil f. Filtergehäuse Kit de part. infér. du carter filtre		1	1	1
90	6220209	Niveauekontakt, kompl. Level switch, compl. Niveauschalter, kompl. Contrôleur de niveau, compl.		x	x	x
91	6220210	Rør Tube Rohr Tube		1	1	1
92	3000296	O-ring O-ring O-Ring Joint torique		1	1	1
93	6200067	Hætte Cap Kappe Capuchon		1	1	1
94	1803634	Låsering Circlip Sicherungsring Circlip		1	1	1
95	1803485	Magnet Magnet Magnet Aimant		1	1	1
96	6200060	Flyder Float Schwimmer Floteur		1	1	1

Maskine, monteret / Machine, mount / Maschine, montiert / Appareil, monté

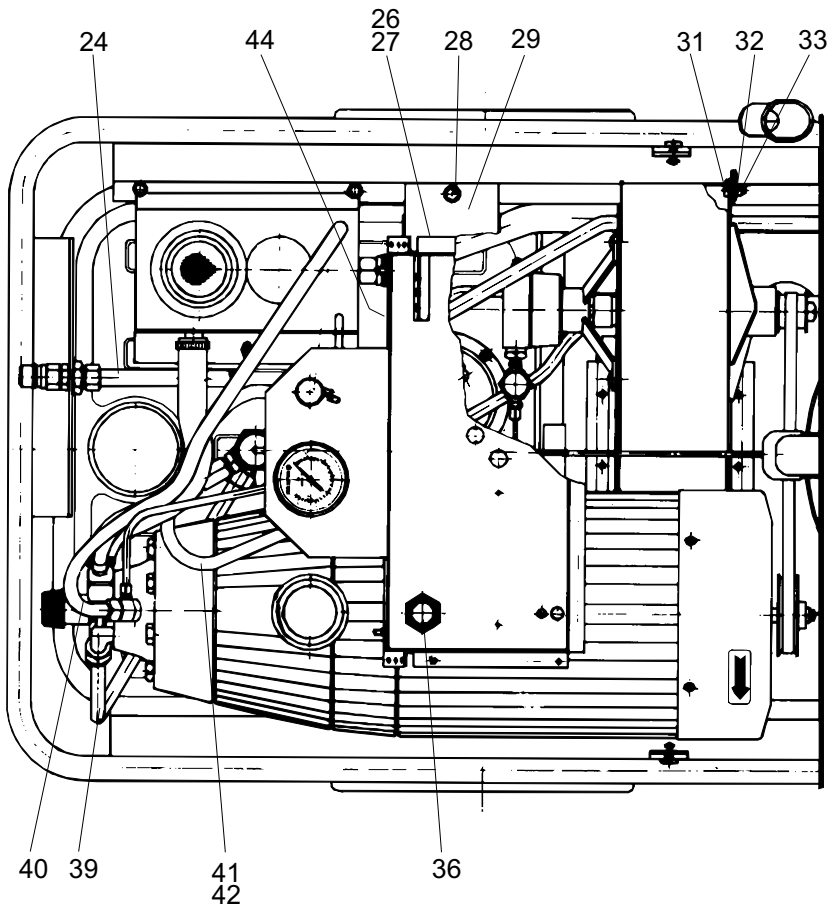
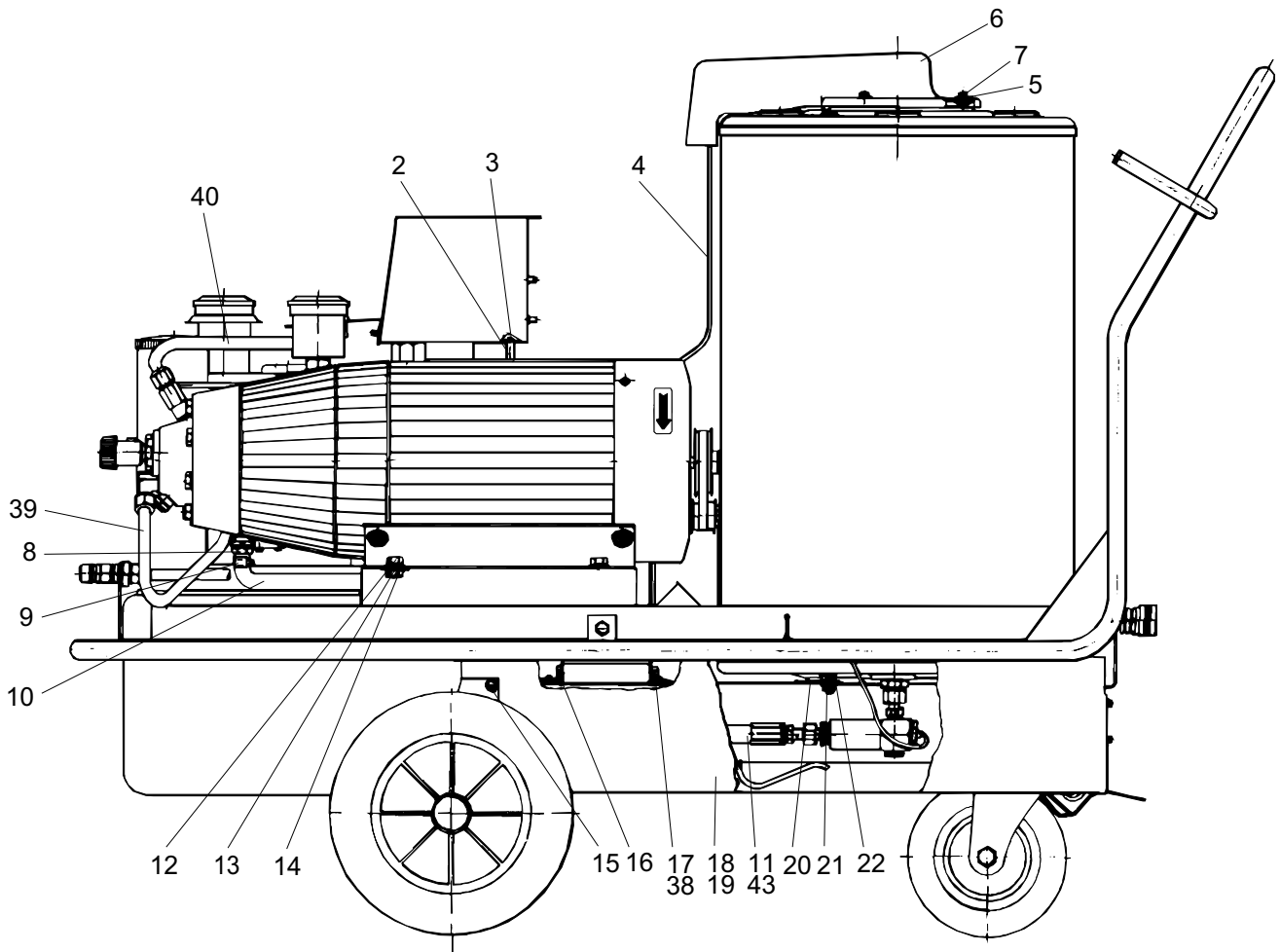

Pos. Ref.	Nr. No.	Betegnels Bezeichnung	Designation Désignation	3803	4203/CS	5003/CS
-	-	Maskine, monteret Machine, mounted Machine, montiert Appareil, monté		x	x	x
2	6220729	Instrumentbeslag Fitting Halteung Garniture		1	1	1
3	1802586	Tapтите skru Tapтите screw Tapтите-schraube Vis Tapтите		1	1	1
4	6220502	Dyserør, kompl. Nozzle lance, compl. Rohr f. Düse, kompl. Tube p. buse, compl.		1	1	1
5	1800440	Skive Washer Scheibe Rondelle		6	6	6
6	6200280	Kedeltop Boiler top section Kessel, oberer Teil Chaudière, partie supérieure		1	1	1
-	6200228	Kedeltop Boiler top section Kessel, oberer Teil Chaudière, partie supérieure	⇒ 01.07.93 N	1	1	1
7	6200310	Top møtrik Nut Mutter Ecrou		3	3	3
-	1800705	Top møtrik Nut Mutter Ecrou	D	3	3	3
8	6300062	Studs Socket Stutzen Raccord		1	1	1
9	1802107	Spændebånd Hose clip Schlauchschelle Collier de serrage		1	1	1
10	6220476	Slange Hose Schlauch Flexible		1	1	1
11	6220557	Intern højtryksslange High pressure hose Hochdruckschlauch Flexible haute pression		1	1	1
12	1800465	Møtrik Nut Mutter Ecrou		4	4	4
13	1800317	Skive Washer Scheibe Rondelle		8	8	8
14	1800762	Skrue Screw Schraube Vis		4	4	4
15	1803592	Skrue Screw Schraube Vis	B 12x13	6	6	6
16	1804087	Bolt Bolt Bolzen Boulon		1	1	1
17	1803725	Møtrik Nut Mutter Ecrou		1	1	1
18	6220077	Dækplade, venstre Cover plate, left Abschlußdeckel, links Couverture, gauche		1	1	1

Pos. Ref.	Nr. No.	Betegnels Bezeichnung	Designation Désignation	3803	4203/CS	5003/CS
19	6220078	Dækplade, højre Cover plate, right Abschlußdeckel, rechts Couverture, droite		1	1	1
20	6200093	Skive Washer Scheibe Rondelle		3	3	3
21	1800515	Møtrik Nut Mutter Ecrou		3	3	3
22	1800796	Skive Washer Scheibe Rondelle		3	3	3
24	6220501	Trykrør, afgang Pressure pipe, outlet Druckrohr, Auslaß Tuyau en départ		1	1	1
26	1800705	Møtrik Nut Mutter Ecrou		2	2	2
27	1800903	Skive Washer Scheibe Rondelle		3	3	3
28	1803592	Skrue Screw Schraube Vis		1	1	1
29	6220726	Beslag Fittings Halteung Garniture		1	1	1
31	1800432	Skrue Screw Schraube Vis		1	1	1
32	6223089	Skive Washer Scheibe Rondelle		1	1	1
33	1800457	Låsemøtrik Lock nut Gegenmutter Ecrou de blocage		1	1	1
36	1800341	Kontramøtrik Lock nut Gegenmutter Contre écrou		1	1	1
38	1801398	Skive Washer Scheibe Rondelle		1	1	1
39	6220510	Trykrør start/stop Pressure pipe, outlet s/s Druckrohr, Start/Stopp Tuyau marche/arrêt	01.04.90 ⇒	1	1	1
-	6401300	Trykrør start/stop Pressure pipe, outlet s/s Druckrohr, Start/Stopp Tuyau marche/arrêt	⇒ 01.04.90	1	1	1
40	2402675	Slange Hose Schlauch Flexible		1	1	1
41	2402949	Slange blå Hose blue Schlauch blau Flexible bleu		1	1	1
42	1801034	Spændebånd Hose clip Schlauchschelle Collier de serrage		2	2	2
43	1801075	Tætningsskive Sealing washer Dichtungsscheibe Rondelle d'étanchéité		1	1	1
44	6401302	Meldeledning start/stop Alarm lead Start/stop Alarmleitung Start/stopp Fil indicateur départ/arrêt	⇒ 01.03.88	1	1	1

50

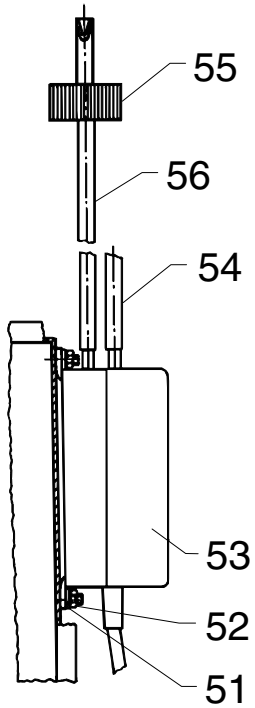

60

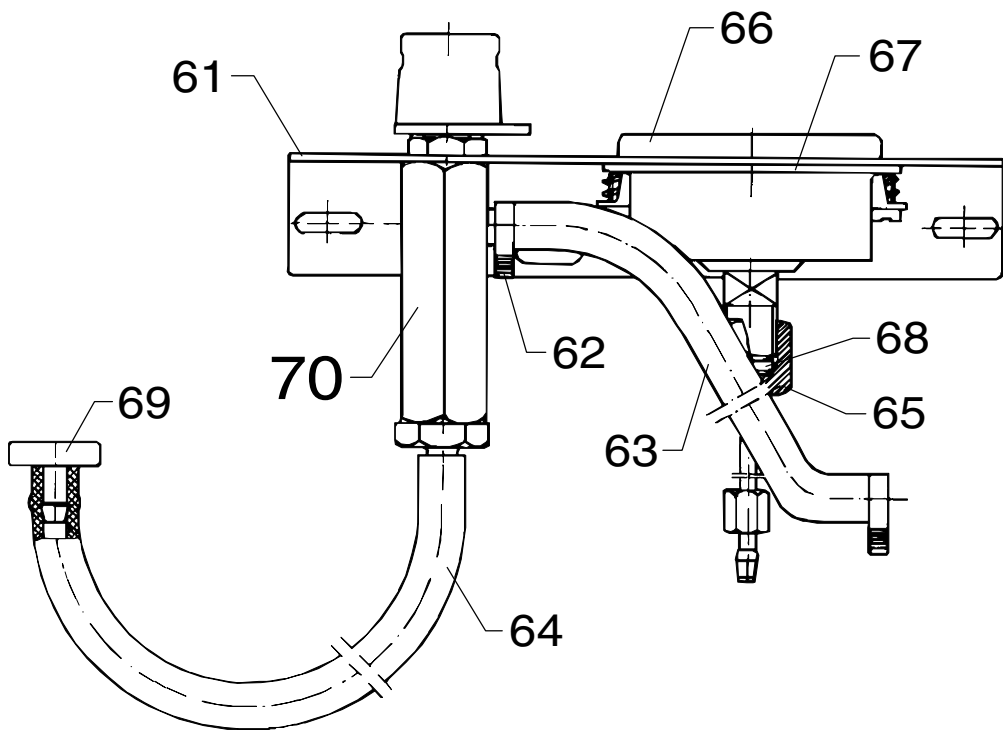
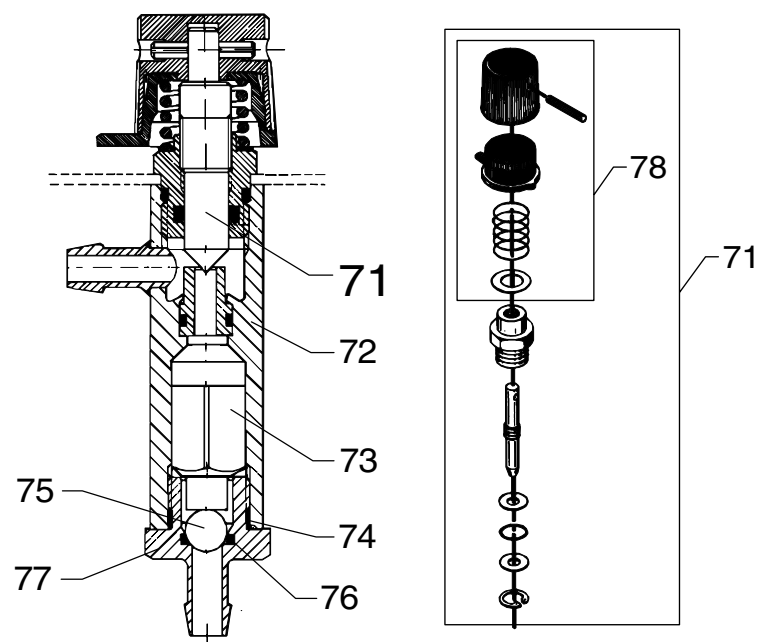

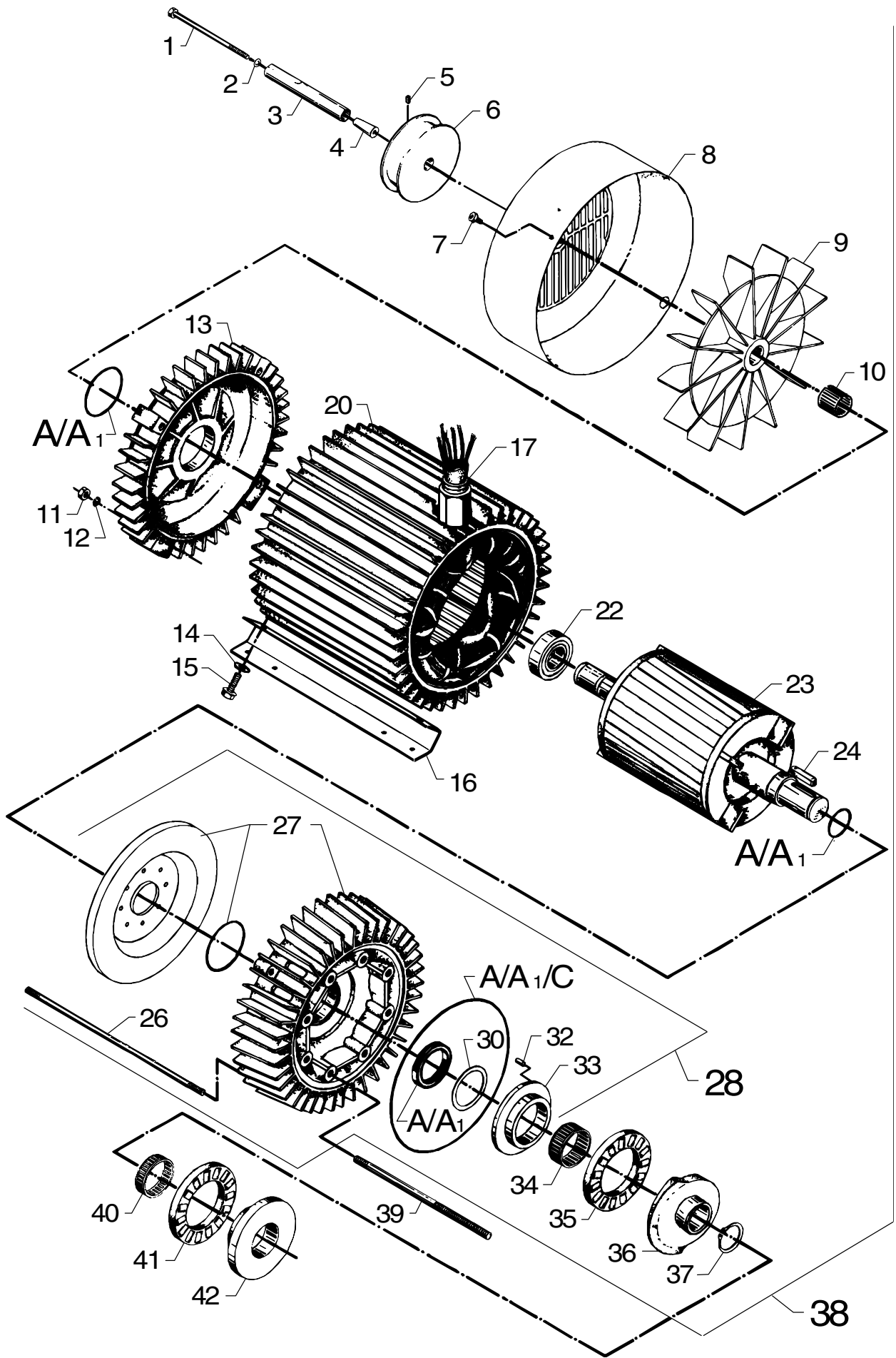

Pos. Ref.	Nr. No.	Betegnels Bezeichnung	Designation Désignation	3803	4203/CS	5003/CS
1	6200415	Bolt Stud Bolzen Boulon		1	1	1
2	1802727	Skive Washer Scheibe Rondelle		1	1	1
3	6200413	Aksel Shaft Welle Arbre		1	1	1
4	6200414	Konus Cone Kegel Cône		1	1	1
5	1800358	Skrue Screw Schraube Vis		1	1	1
6	6200434	Remskive Pulley Riemenscheibe Poulie	50Hz	1	1	1
6	6200435	Remskive Pulley Riemenscheibe Poulie	60Hz	1	1	1
7	1803543	Skrue Screw Schraube Vis	M4x10	2	2	2
8	6100609	Ventilatorskærm Fan guard Ventilatorschutzblech Capot ventilateur		1	1	1
9	6100607	Ventilator m. skrue Fan w. screw Ventilator m. Schraube Ventilateur avec vis		1	1	1
10	1802503	Låsering Circlip Sicherungsring Circlip		1	1	1
11	1803725	Møtrik Nut M8 Mutter Ecrou		4	4	4
12	1801182	Fjederskive Spring washer Federscheibe Rondelle ressort		4	4	4
13	6100611	N-lejedæksel Rear bearing cover N-Lagerdeckel AR-flasque de carter		1	1	1
14	1801968	Skive Washer Scheibe Rondelle		4	4	4
15	1802651	Bolt Stud Bolzen Boulon		4	4	4
16	6220073	Motorfod Holder f. motor Halter f. Motor Support moteur		2	2	2
17	6220727	Bøsning Bush Buchse Baque		1	1	1
20	-	Stator med statorhus Stator with stator housing Stator mit Statorgehäuse Stator avec enveloppe de stator		Se side 21 See page 21 SieheSeite 21 Voir page 21		
22	3200623	N-leje Rear bearing N-Lager AR-roulement		1	1	1

Pos. Ref.	Nr. No.	Betegnels Bezeichnung	Designation Désignation	3803	4203/CS	5003/CS
23	-	Aksel med rotor Shaft with rotor Welle mit Rotor Rotor				
-	6100998		L=145mm	1		
-	6101001		L=190mm		1	
-	6101000		L=170mm			1
24	3200672	Feder Key Federkeil Clavette		1	1	1
26	6100712	Stagbolt Stud Stehbolzen Entretoise		4	4	4
27	6101749	D-lejedæksel Front bearing cover D-Lagerdeckel AV-flasque de carter		1	1	1
28	6101750	D-lejedæksel, komplet Front bearing cover, complete D-Lagerdeckel, komplett AV-flasque de carter, compl.		x	x	x
30	6100995	Skive Washer Scheibe Rondelle		1	1	1
32	6100996	Styrestift Guide pin Kegelstift Goupille		1	1	1
33	6100943	Lejeskive Bearing track Lagerscheibe Rondelle de palier		1	1	1
34	3200656	Nåleleje Needle bearing Nadellager Roulement à aiguille		1	1	1
35	3200615	Rulleleje Roller bearing Rollenlager Roulement		1	1	1
36	6100962	Skråskive Wobble disc 4 Taumelscheibe Disque oblique	5.0 kW, 60 Hz	1		
-	6100962	4	5.5 kW, 60 Hz		1	
-	6100964	6	6.5 kW, 60 Hz		1	1
-	6100969	11	5.5 kW, 50 Hz		1	
-	6100970	12	6.5 kW, 50 Hz			1
37	1802511	Seegerring Segeer circlip ring Seegerring Circlip		1	1	1
38	-	Motor, komplet Motor, complete Motor, komplett Moteur, compl.		Se side 21 See page 21 SieheSeite 21 Voir page 21		
39	6100710	Stagbolt Stud Stehbolzen Entretoise		8	8	
39	6301368	Stagbolt Stud Stehbolzen Entretoise	C3VA		8	8
40	3200664	Nåleleje Needle bearing Nadellager Roulement à aiguille		1	1	1
41	3200615	Aksialrulleleje Axial roller bearing Axialrollenlager Roulement		1	1	1
42	6100945	Lejeskive Bearing track Lagerscheibe Plaque de palier		1	1	1

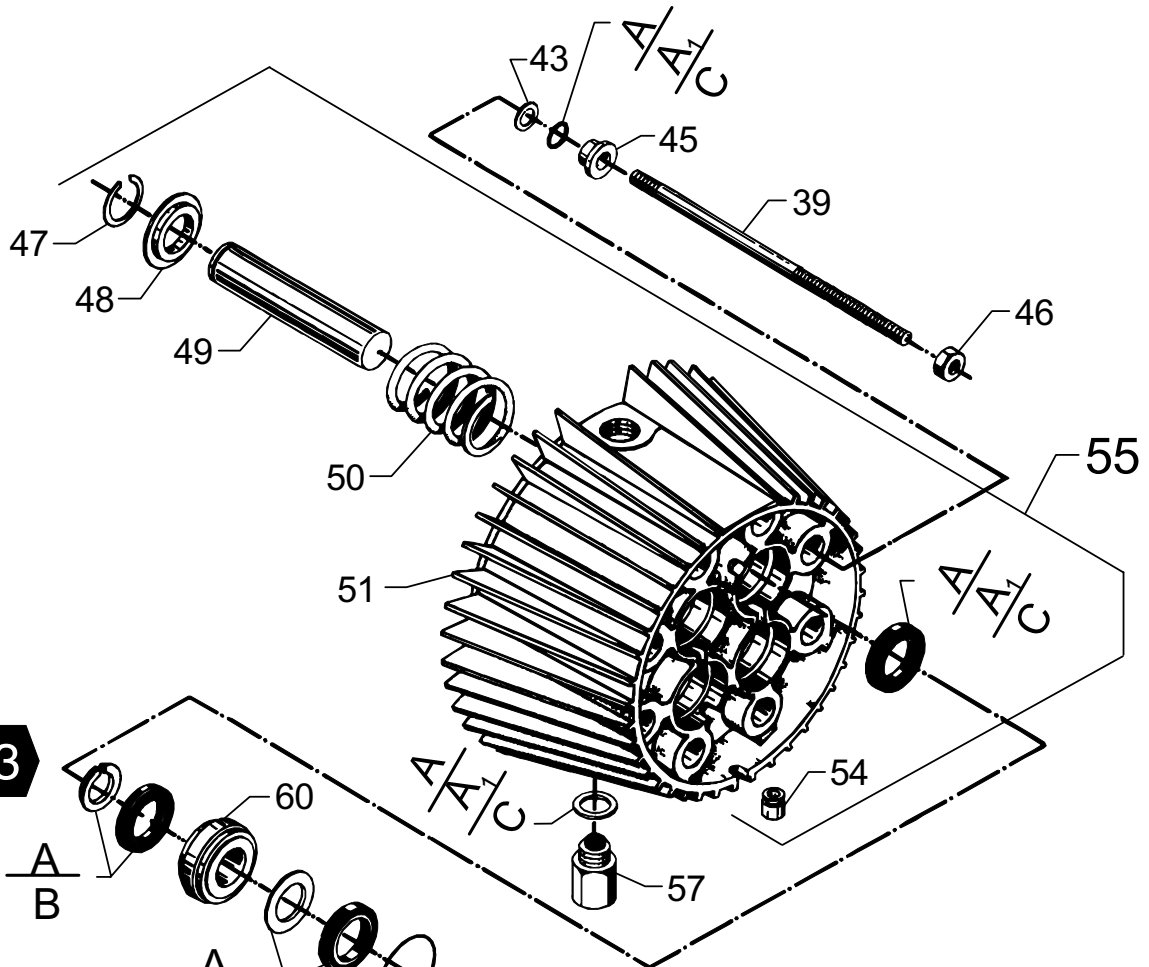

03

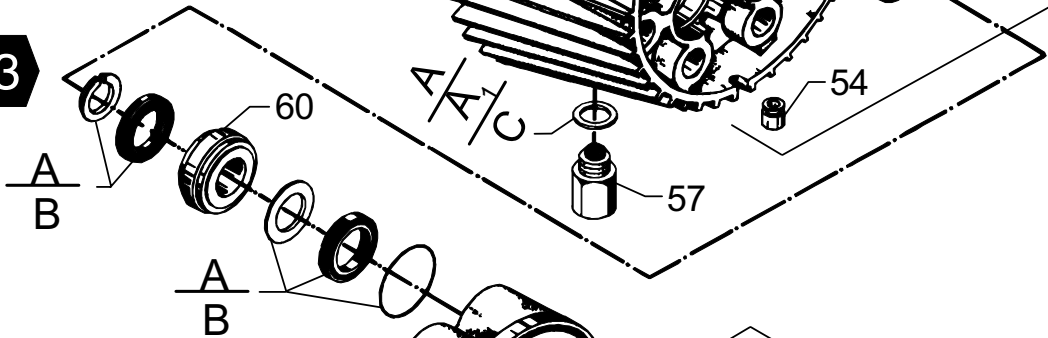

C3

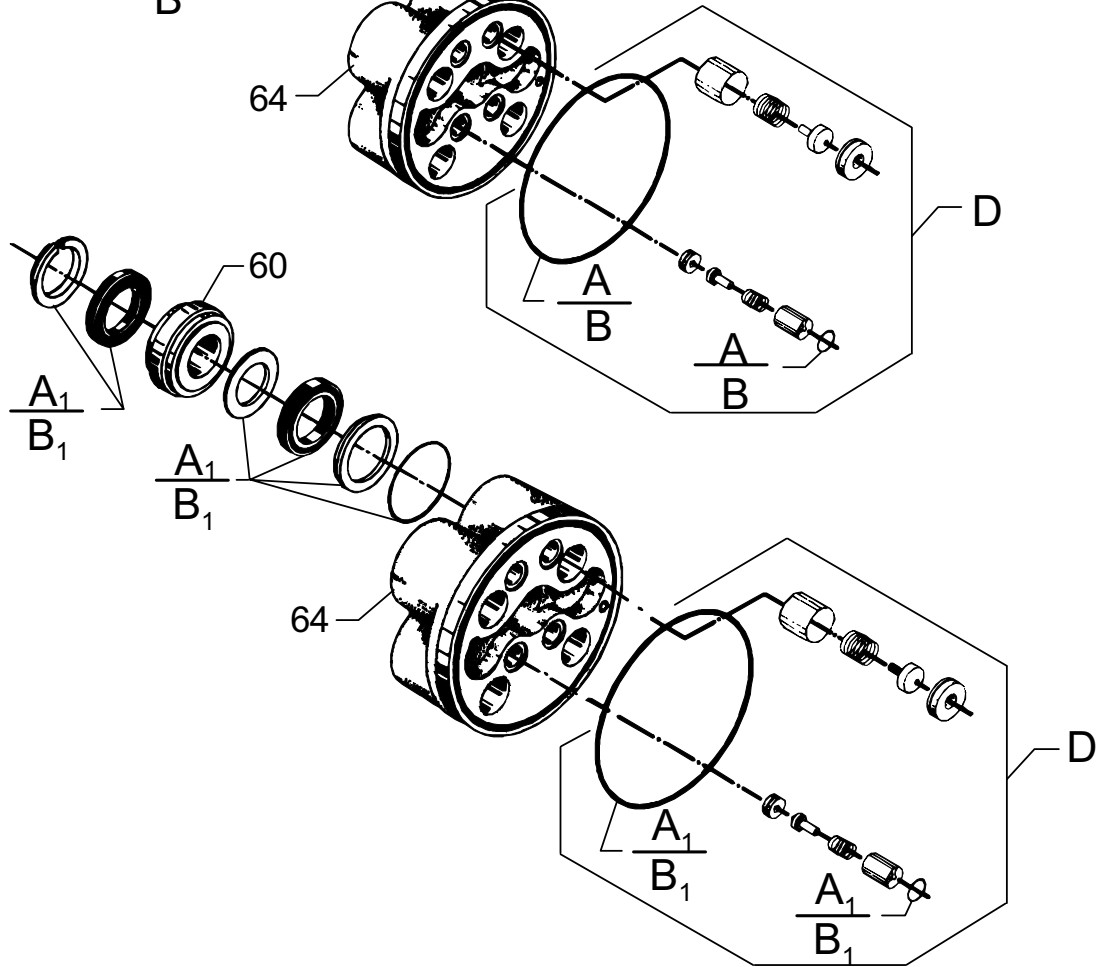

303mp020

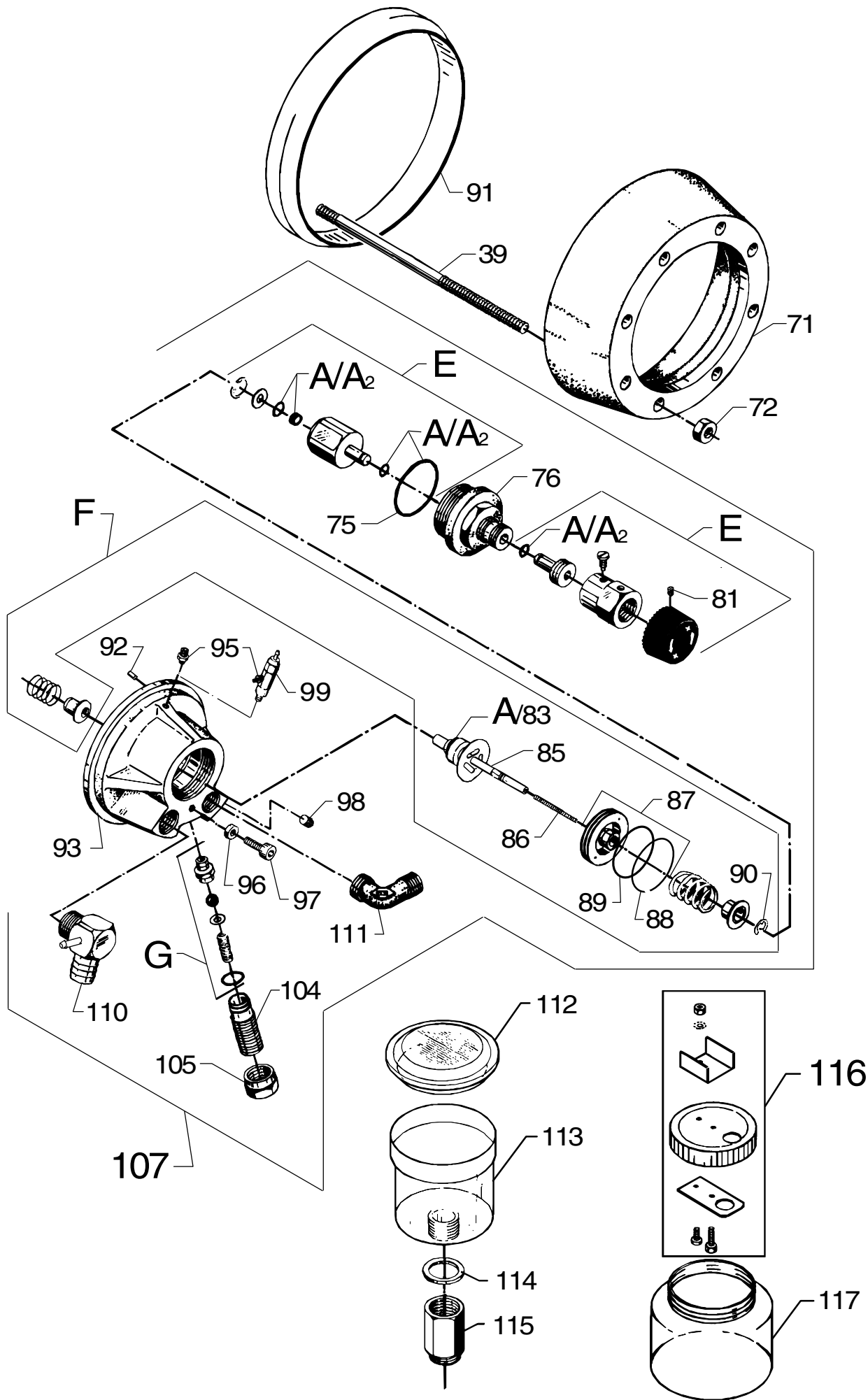

Pos. Ref.	Nr. No.	Betegnels Bezeichnung	Designation Désignation	3803	4203/CS	5003/CS
A₂	1119568	Rep.sæt, pakninger f. omløbsv. Rep.kit, gaskets f. by-pass v. Rep.satz, Dichtungen f. Umlaufv. Kit de joints p. soupape by-pass	C3VA		x	x
E	1118538	Rep.sæt, greb f. omløbsventil, Kit, adj. mechanism f. by-pass valve Satz, Justiereinrichtung f. Umlaufven. Kit, bouton de soupape by-pass		x	x	x
F	1118579	Rep.sæt, omløbsventil Rep.kit, by-pass valve Rep.satz, Umlaufventil Kit de soupape by-pass	03V	x	x	x
F	1118580	Rep.sæt, omløbsventil Rep.kit, by-pass valve Rep.satz, Umlaufventil Kit de soupape by-pass	03/C3VA	x	x	x
G	1118512	Rep.sæt, sikkerhedsventil Rep.kit, safety valve Rep.satz, Überdruckventil Kit de soupape de sûreté		x	x	x
71	6100602	Spændering Retaining ring Spannring Flaque AV pompe		1	1	1
72	1800465	Møtrik M10 Nut Mutter Ecrou		8	8	8
75	3001179	O-ring O-ring O-Ring Joint torique		1	1	1
76	6100984	Bøsning Bushing Buchse Manchon		1	1	1
81	1802602	Kraterskrue Crater-point screw Kraterschraube Vis		1	1	1
83	3000460	O-ring O-ring O-Ring Joint torique		1	1	1
85	6220558	Ventilkegle, komplet Valve cone, complete Ventil kegel, komplett Cône p. clapet, compl.	V	1	1	1
85	6400143	Ventilkegle, komplet Valve cone, complete Ventil kegel, komplett Cône p. clapet, compl.	VA		1	1
86	2600286	Fjeder Spring Feder Ressort		1	1	1
87	6100925	Stempel, kompl. Piston, compl. Kolben, komplett Piston, compl.		1	1	1
88	6101061	Stempelring Piston ring Kolbenring Anneau piston		1	1	1
89	3001716	O-ring O-ring O-Ring Joint torique		1	1	1
90	6101069	Seegerring Seeger circlip ring Seegerring Anneau		1	1	1
91	6301392	Ring Ring ø 160, Ring Anneau	C3VA		1	1
92	6100996	Styrestift Guide pin Kegelstift Goupille		1	1	1

Pos. Ref.	Nr. No.	Betegnels Bezeichnung	Designation Désignation	3803	4203/CS	5003/CS
93	6101042	Ventildæksel Valve cover Ventildeckel Corp by-pass		1	1	1
95	1603422	Forskruning Threaded connection Verschraubung Raccord fileté		1	1	1
96	6100985	Låseskive Lock washer Haltescheibe Disque de blocage		1	1	1
97	1802636	Skrue Screw Schraube Vis		1	1	1
98	1602333	Rørprop Pipe plug Rohrschlußstück Bouchon		1	1	1
99	-	Udluftningsventil, kompl. Venting valve, compl. Entlüftungsventil, kompl. Vis de purge, compl		Se side 23 See page 23 SieheSeite 23 Voir page 23		
104	6100940	Justerskrue Adjusting screw Justierschraube Vis de réglage		1	1	1
105	6100928	Kontramøtrik Lock nut Gegenmutter Contre écrou		1	1	1
107	6220551	Omløbsventil, komplet By-pass valve, complete Umlaufventil, komplett Soupape by-pass, compl.	V	x	x	x
107	6220595	Omløbsventil, komplet By-pass valve, complete Umlaufventil, komplett Soupape by-pass, compl.	VA	x	x	x
110	6220681	Vinkel Elbow Winkel Coudé entrée		1	1	1
111	1600444	Vinkel Elbow Winkel Coudé sortie		1	1	1
112	2201854	Låg f. olieglas Cover f. oil reservoir Deckel f. Ölbehälter Couvercle réservoir d'huile		1	1	1
113	2201846	Olieglas Oil reservoir Ölbehälter Réservoir d'huile		1	1	1
114	3000361	Kobbberskive Copper washer Kupferscheibe Rondelle en cuivre		1	1	1
115	6160610	Studs Socket Stutzen Raccord		1	1	1
116	6101625	Rep.sæt, låg f. slamglas Rep.kit, cover f. sludge container Rep.satz, Deckel f. Schlammglas Kit, couvercle, resv.d' huiles usée		1	1	1
117	2200467	Slamglas Sludge container Schlammglas Réservoir d'huile usée		1	1	1

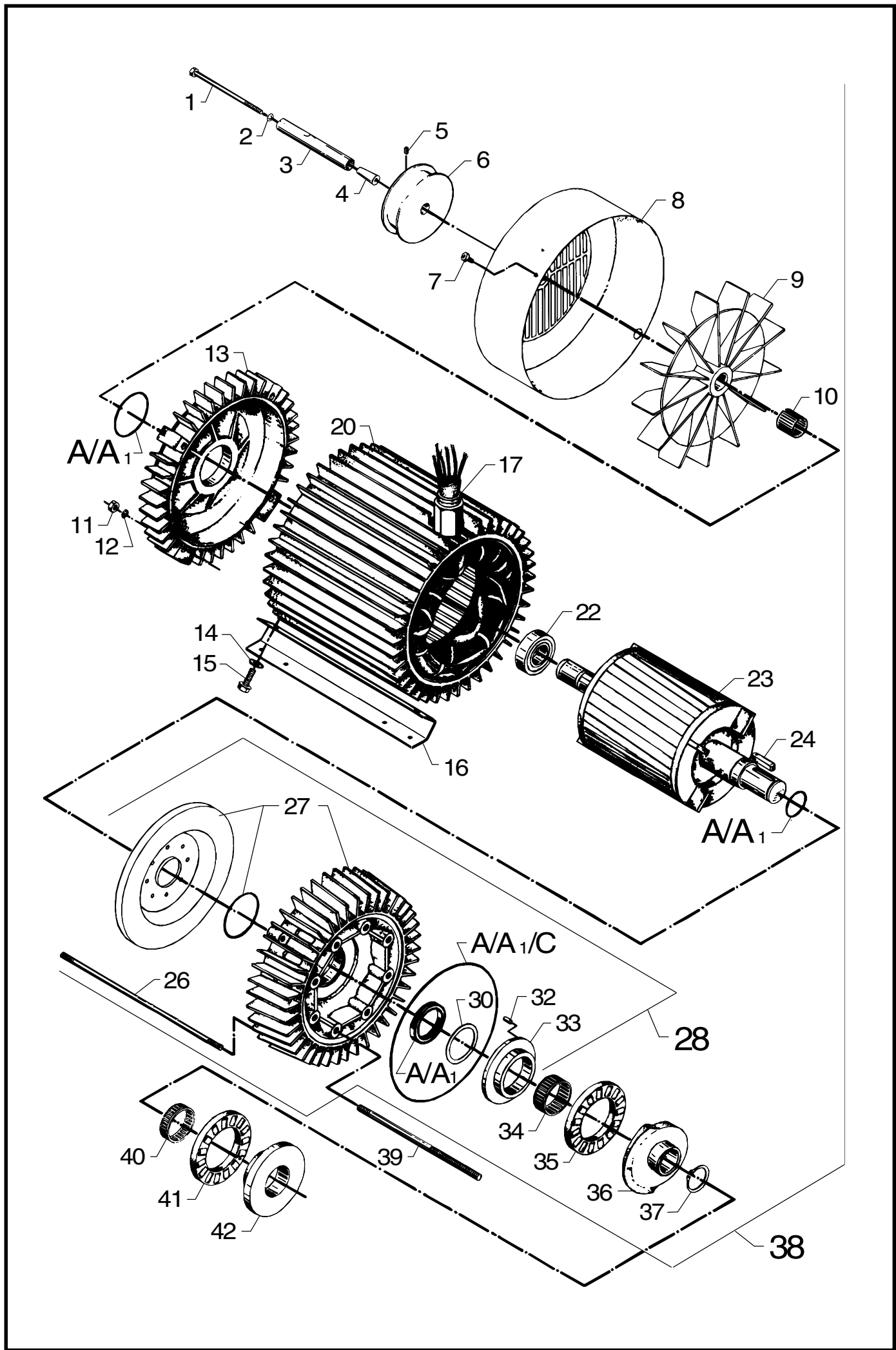

Dæmpecylinder / Regulating cylinder / Regulierzylinder für Öldruck / Régulateur pression fuel

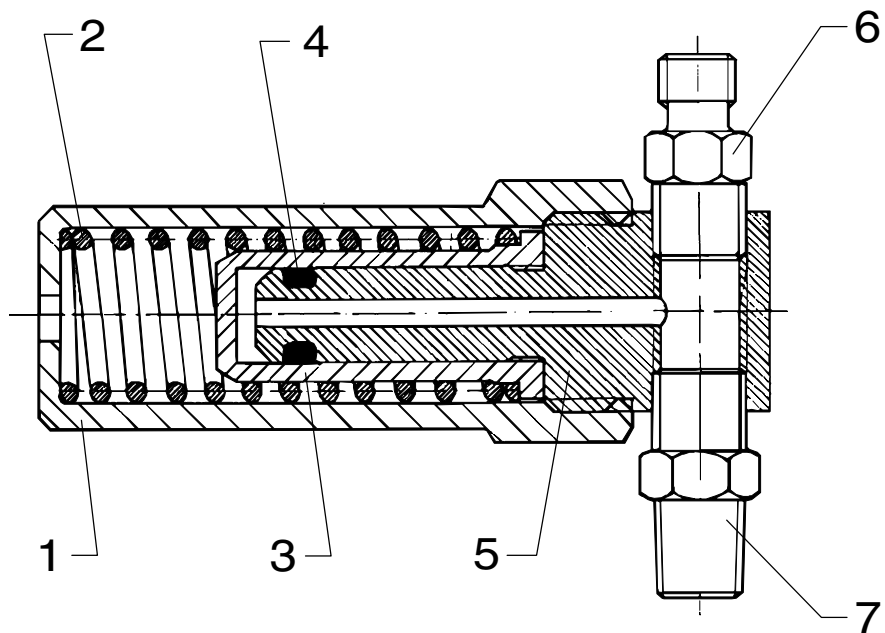

Udluftningsventil / Venting valve / Entlüftungsventil / Vis de purge

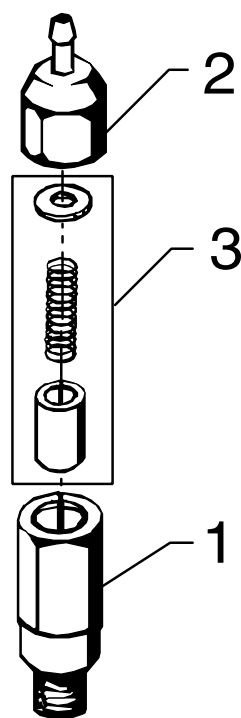

6220555

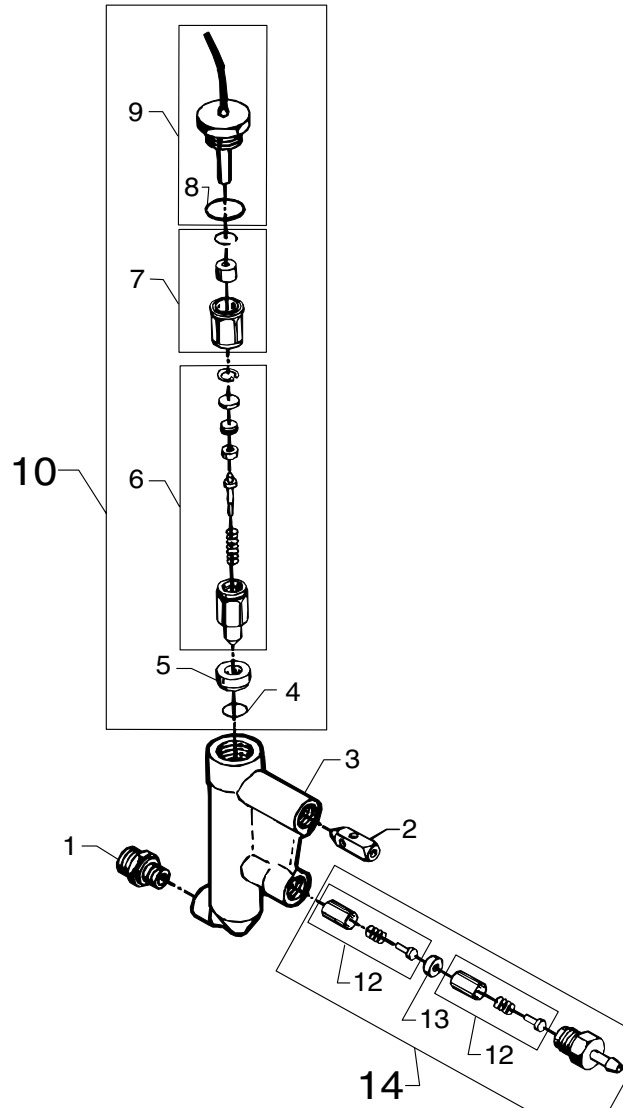
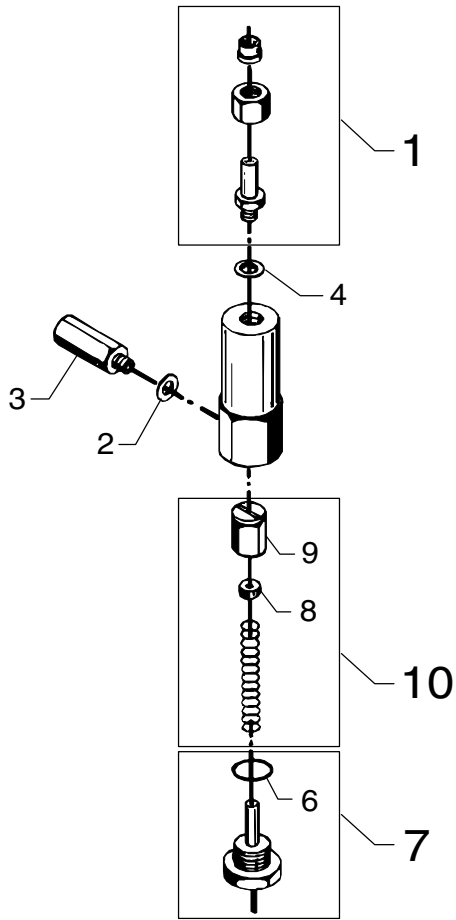

6228551

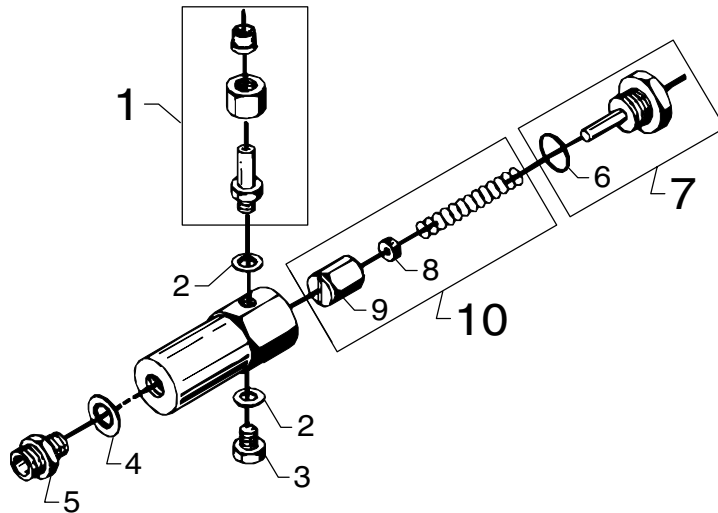

Pos. Ref.	Nr. No.	Betegnels Bezeichnung	Designation Désignation	3803	4203/C3	5003/C3
-	6220555	Strømningskontakt (afgang) Flow switch, (outlet) Strömungsschalter (Auslaß) Circulation sélecteur (sortie)		x	x	x
1	6220554	Forskruning Threaded connection Verschraubung Raccord fileté		1	1	1
2	1803493	Tætningsskive Sealing washer Dichtungsscheibe Rondelle d'étanchéité		1	1	1
3	6220530	Hus Housing Gehäuse Corps		1	1	1
4	1801075	Tætningsskive Sealing washer Dichtungsscheibe Rondelle d'étanchéité		1	1	1
6	3000825	O-ring O-ring O-Ring Joint torique		1	1	1
7	6221773	Reedkontakt m. O-ring Reed switch with O-ring Reedschalter mit O-ring Reed sélecteur avec joint torique		1	1	1
8	1803485	Magnet Magnet Magnet Aimant		1	1	1
9	6200554	Stempel Piston Kolben Piston		1	1	1
10	1119701	Rep.sæt, strømningsskontakt Rep.kit, flow switch Rep.satz, Strömungsschalter Kit de rép., circulation sélecteur		1	1	1
-	6228551	Strømningskontrol Flow control, complete Strömungswächter, komplett Contrôleur de débit, compl.		x	x	x
1	6200558	Forskruning Threaded connection Verschraubung Raccord fileté		1	1	1
2	1803493	Tætningsskive Sealing washer Dichtungsscheibe Rondelle d'étanchéité		2	2	2
3	6200529	Aftapningsprop Drain plug Ablaßschraube Bouchon		1	1	1
4	1801075	Tætningsskive Sealing washer Dichtungsscheibe Rondelle d'étanchéité		1	1	1
5	1601079	Forskruning Threaded connection Verschraubung Raccord fileté		1	1	1
6	3000825	O-ring O-ring O-Ring Joint torique		1	1	1
7	6221773	Reedkontakt m. O-ring Reed switch with O-ring Reedschalter mit O-ring Reed sélecteur avec joint torique		1	1	1
8	1803485	Magnet Magnet Magnet Aimant		1	1	1

Pos. Ref.	Nr. No.	Betegnels Bezeichnung	Designation Désignation	3803	4203/C3	5003/C3
9	6200554	Stempel Piston Kolben Piston		1	1	1
10	1119701	Rep.sæt, strømningsskontakt Rep.kit, flow switch Rep.satz, Strömungsschalter Kit de rép., circulation sélecteur		1	1	1
-	6200574	Strømningskontrol (start/stop) Flow control (s/s) 01.02.90 ⇒ Strömungswächter (Start/Stop) Contrôleur de débit (marche/arr.)		x	x	x
1	1602770	Forskruning Threaded connection Verschraubung Raccord fileté		1	1	1
2	6101038	Stempel Piston Kolben Piston		1	1	1
3	6201545	Hus Housing Gehäuse Corps		1	1	1
4	3001112	O-ring O-ring O-Ring Joint torique		1	1	1
5	6201534	Sæde Seat Sitz Siège		1	1	1
6	6350463	Stempel, kompl. Piston, compl. Kolben, kompl. Piston, compl.		1	1	1
7	6350454	Stempel, kompl. Piston, compl. Kolben, kompl. Piston, compl.		1	1	1
8	3000825	O-ring O-ring O-Ring Joint torique		1	1	1
9	6221773	Reedkontakt m. O-ring Reed switch with O-ring Reedschalter mit O-ring Reed sélecteur avec joint torique		1	1	1
10	1119319	Rep.sæt, strømningsskontrol Rep.kit, flow control Rep.satz, Strömungswächter Kit de rép., contrôleur de débit		1	1	1
12	1119566	Rep. sæt, kontraventil Rep. kit, nonreturn valve Rep. satz, Rückschlagventil Kit de rép., clapet anti-retour		2	2	2
13	6201535	Sæde Seat Sitz Siège		1	1	1
14	1119318	Rep.sæt, kontraventil Rep.kit, nonreturn valve Rep.satz, Rückschlagventil Kit de rép., clapet anti retour		1	1	1

6200939

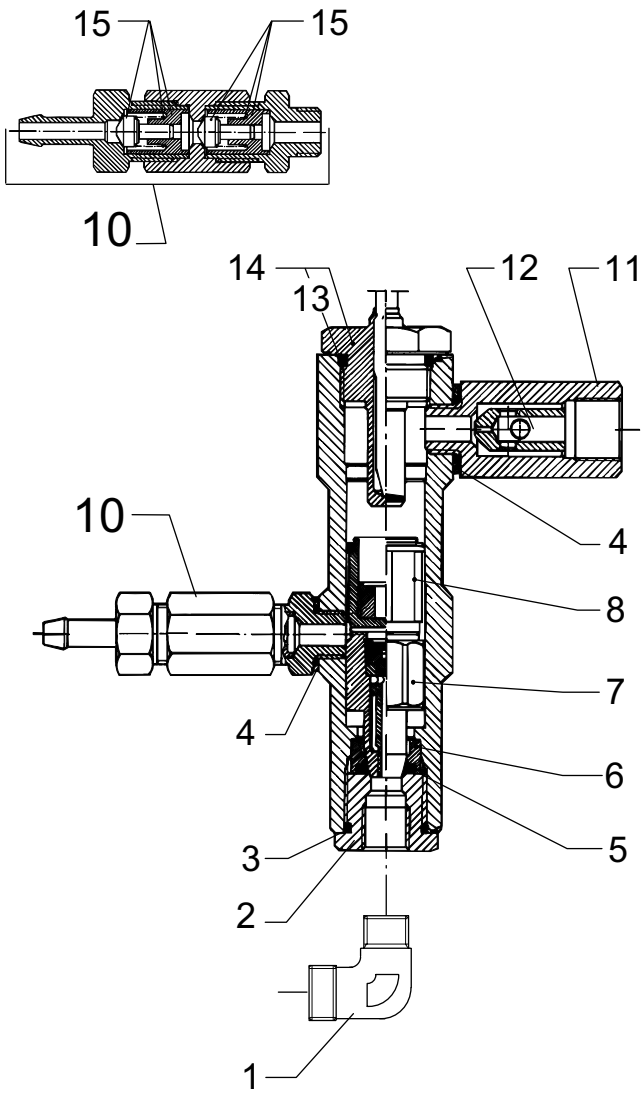

6228350

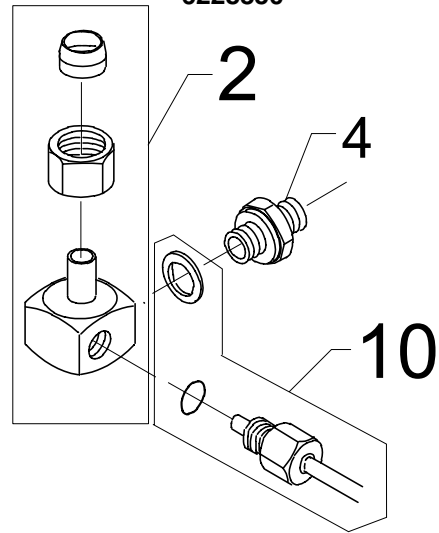

6228357 (AUS)

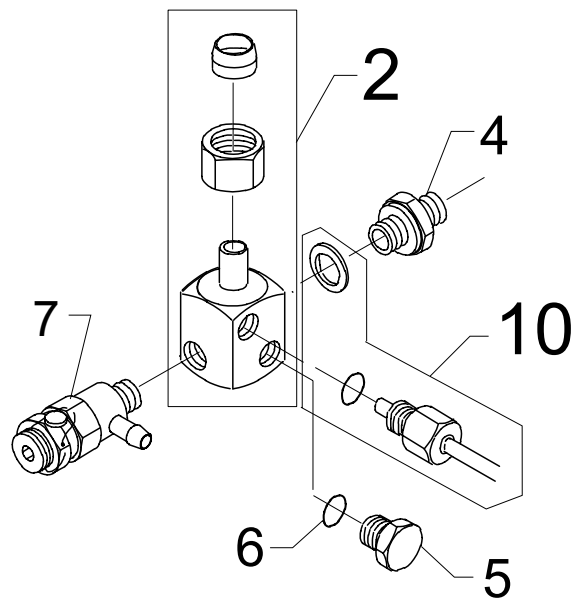

6228354 (N, S)

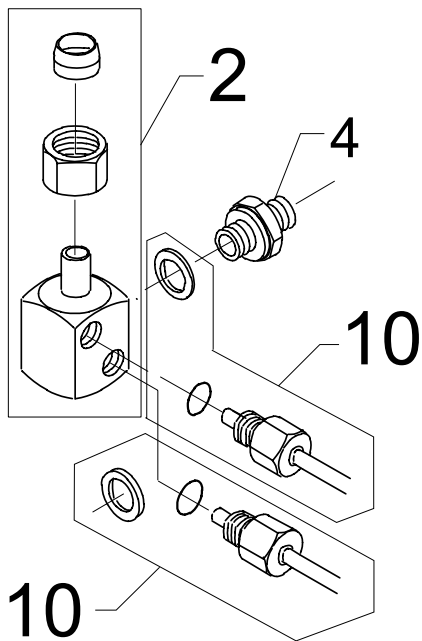

6228355 (SF)

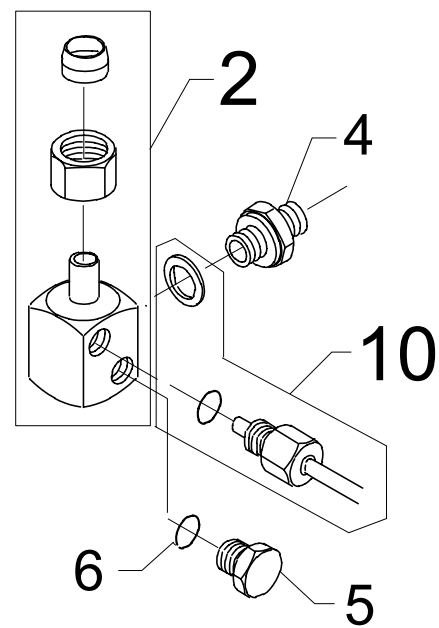

Pos. Ref.	Nr. No.	Betegnels Bezeichnung	Designation Désignation	3803	4203/CS	5003/CS
-	6200939	Strömungskontakt (start/stop) Flow switch (s/s) ⇒ 01.02.90 Strömungsschalter (Start/Stop) Circulation sélecteur (marche/arr.)		x	x	x
1	1603119	Vinkel Elbow Winkel Raccord coudé		1	1	1
2	6300438	Omløber Union nut Überwurfmutter Ecrou-raccord		1	1	1
3	3000262	O-ring O-ring O-Ring Joint torique		1	1	1
4	1803493	Tætningsskive Sealing washer Dichtungsscheibe Rondelle d'étanchéité		2	2	2
5	3001112	O-ring O-ring O-Ring Joint torique		1	1	1
6	6350625	Sæde Seat Sitz Siège		1	1	1
7	6350463	Stempel, kompl. Piston, compl. Kolben, kompl. Piston, compl.		1	1	1
8	6350454	Stempel, kompl. Piston, compl. Kolben, kompl. Piston, compl.		1	1	1
10	6200938	Kontraventil, kompl. Nonreturn valve, compl. Rückschlagventil, kompl. Clapet anti-retour, compl.		1	1	1
11	6220530	Hus Housing Gehäuse Corps		1	1	1
12	6101038	Stempel Piston Kolben Piston		1	1	1
13	3000825	O-ring O-ring O-Ring Joint torique		1	1	1
14	6221773	Reedkontakt m. O-ring Reed switch with O-ring Reedschalter mit O-ring Reed sélecteur avec joint torique		1	1	1
15	1119566	Rep. sæt, kontraventil Rep. kit, nonreturn valve Rep. satz, Rückschlagventil Kit de rép., clapet anti-retour		2	2	2
-	1602325	Prop Plug Pfropfen Bouchon	11.09.92 ⇒	1	1	1
-	6228350	Spiralafgangsvinkel, komplet Outlet for coil, elbow, complete Auslass für Heizschlange, Winkel Sortie serpentin coudée, compl.		x	x	x
2	6200360	Spiralafgangsvinkel Outlet for coil, elbow Auslass für Heizschlange Sortie serpentin coudée		1	1	1
4	1601079	Forskruning Threaded connection Verschraubung Raccord fileté		1	1	1
10	1119011	Rep.sæt, spiralafgangsvinkel Rep.kit, Outlet coil, elbow Satz, Auslass Heizschlange, Winkel Kit de rép., sortie serpentin coudée		1	1	1

Pos. Ref.	Nr. No.	Betegnels Bezeichnung	Designation Désignation	3803	4203/CS	5003/CS
-	6228354	Spiralafgangsvinkel, komplet Outlet for coil, elbow Auslass für Heizschlange, Winkel Sortie serpentin coudée, compl.	N, S	x	x	x
2	6200381	Spiralafgangsvinkel Outlet for coil, elbow Auslass für Heizschlange Sortie serpentin coudée		1	1	1
4	1601079	Forskruning Threaded connection Verschraubung Raccord fileté		1	1	1
10	1119011	Rep.sæt, spiralafgangsvinkel Rep.kit, Outlet coil, elbow Satz, Auslass Heizschlange, Winkel Kit de rép., sortie serpentin coudée		2	2	2
-	6228357	Spiralafgangsvinkel, komplet Outlet for coil, elbow, complete f. AUS Auslass für Heizschlange, Winkel, komp. Sortie serpentin coudée, compl.		x	x	x
2	6220368	Spiralafgangsvinkel Outlet for coil, elbow Auslass für Heizschlange Sortie serpentin coudée		1	1	1
4	1601079	Forskruning Threaded connection Verschraubung Raccord fileté		1	1	1
5	6200491	Prop Plug Pfropfen Bouton		1	1	1
6	3000973	O-ring O-ring O-Ring Joint torique		1	1	1
7	6220584	Sikkerhedsventil Safety valve Überdruckventil Soupape de sûreté		1	1	1
10	1119011	Rep.sæt, spiralafgangsvinkel Rep.kit, Outlet coil, elbow Rep.satz, Auslass Heizschlange, Winkel Kit de rép., sortie serpentin coudée		1	1	1
-	6228355	Spiralafgangsvinkel, komplet Outlet for coil, elbow Auslass für Heizschlange, Winkel Sortie serpentin coudée, compl.	SF	x	x	x
2	6200381	Spiralafgangsvinkel Outlet for coil, elbow Auslass für Heizschlange Sortie serpentin coudée		1	1	1
4	1601079	Forskruning Threaded connection Verschraubung Raccord fileté		1	1	1
5	6200491	Prop Plug Pfropfen Bouton		1	1	1
6	3000973	O-ring O-ring O-Ring Joint torique		1	1	1
10	1119011	Rep.sæt, spiralafgangsvinkel Rep.kit, Outlet coil, elbow Satz, Auslass Heizschlange, Winkel Kit de rép., sortie serpentin coudée		2	2	2

Kedel / Boiler / Kessel / Chaudière

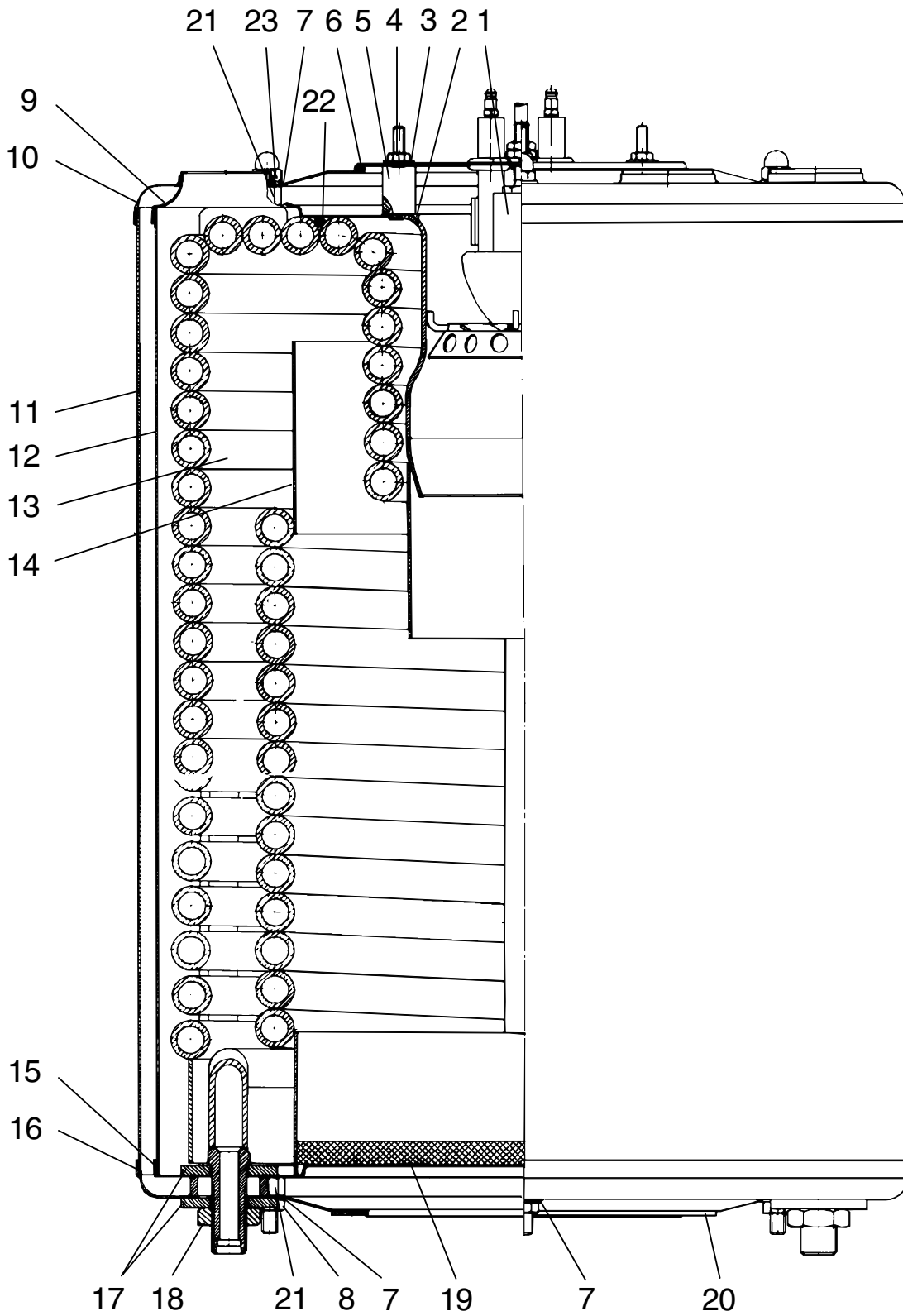

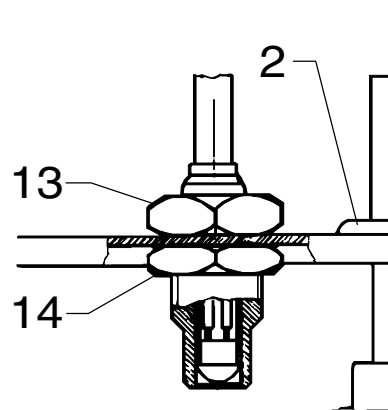
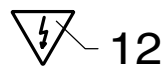
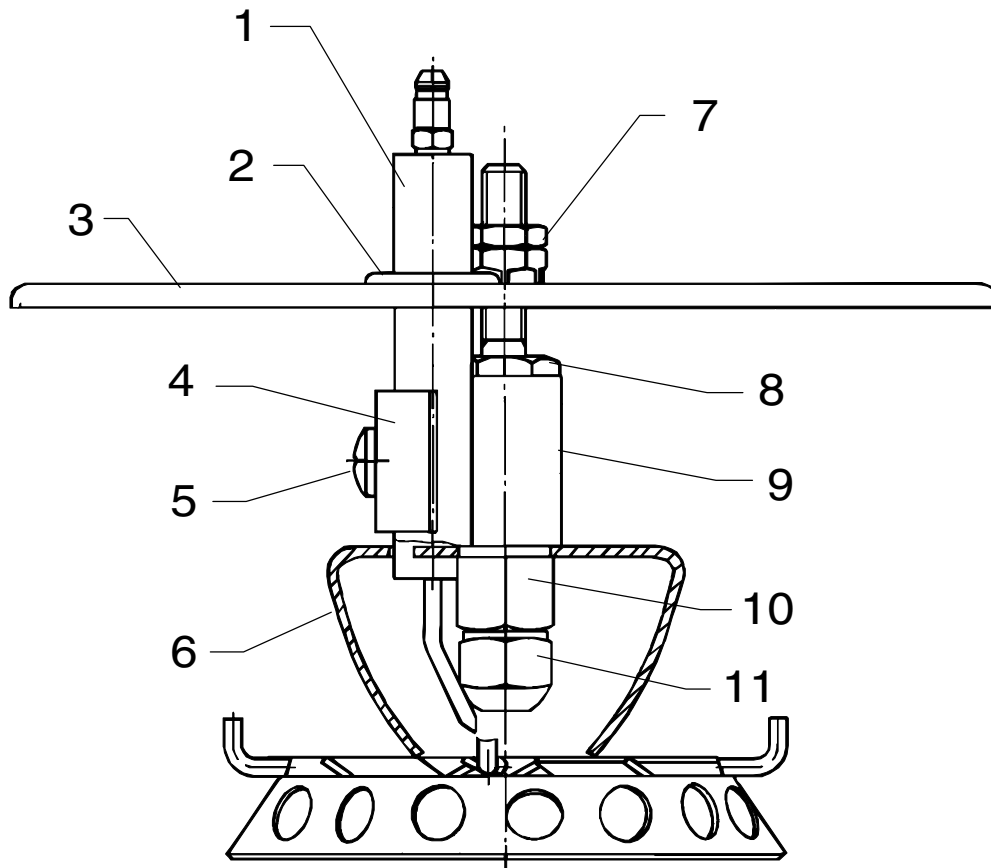

Bläser / Fan / Gebläse / Ventilateur

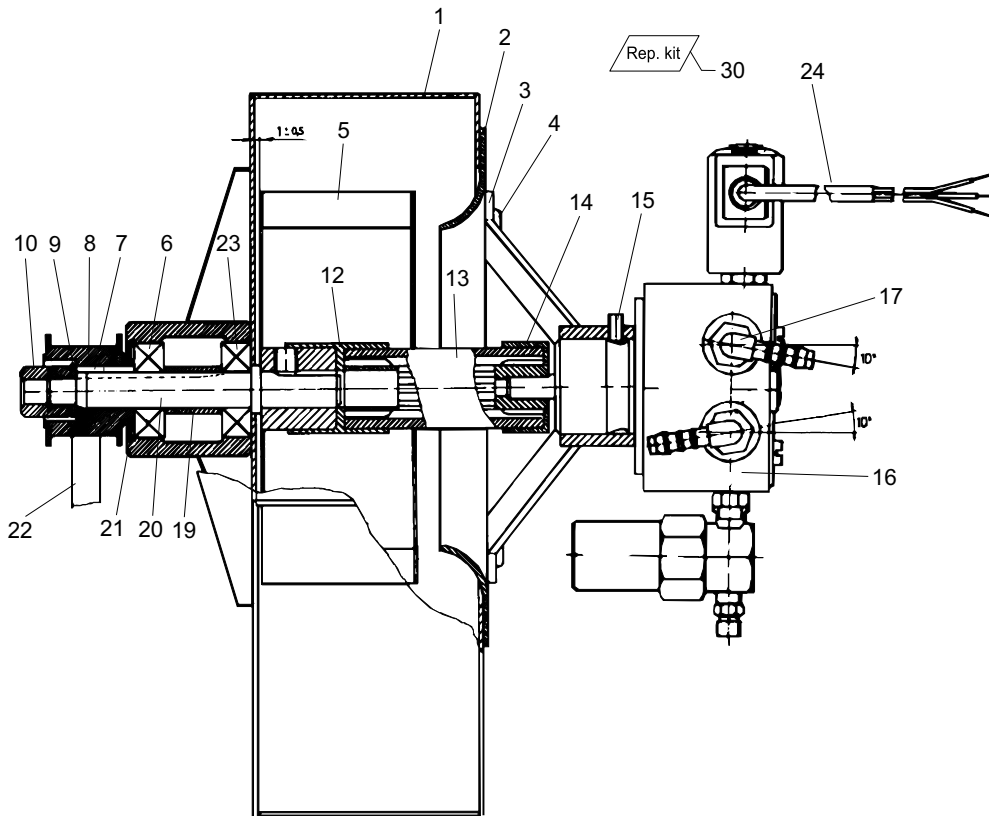

4203V/VA
42C3V/VA

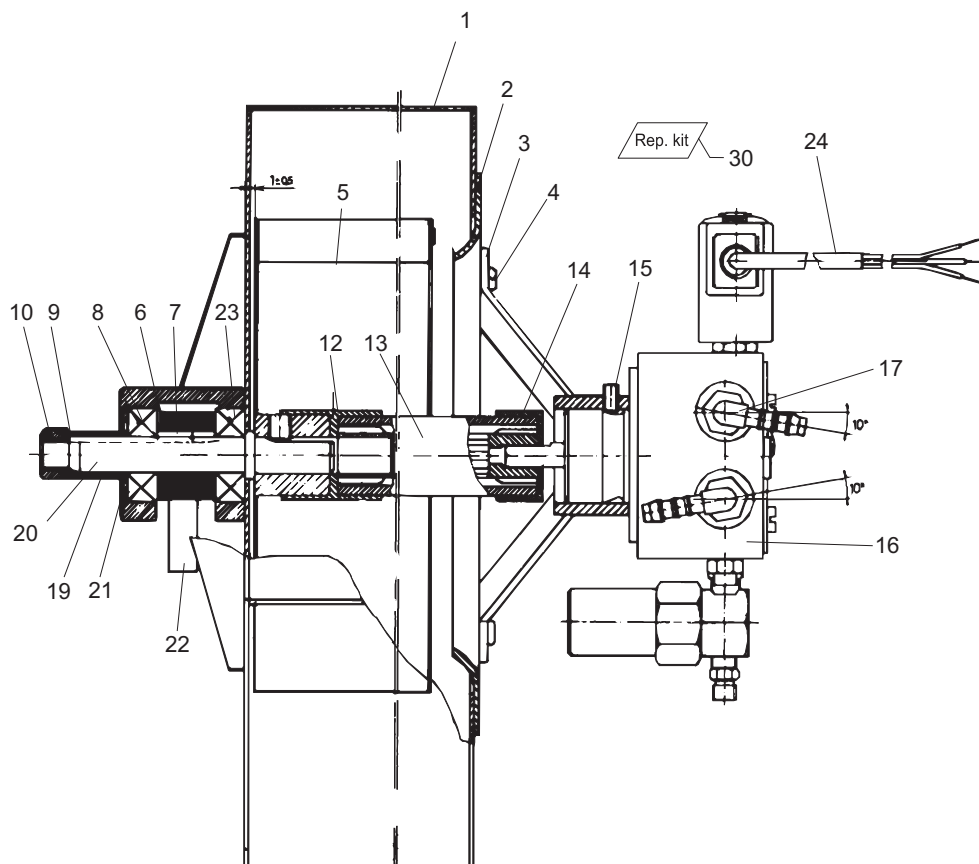

Pos. Ref.	Nr. No.	Betegnels Bezeichnung	Designation Désignation	3803	4203/C3	5003/C3
-	-	Blæser, komplet Fan, complete Gebläse, komplett Ventilateur, compl.				
1	6220451	Blæserhus Fan housing Gehäuse für Gebläse Carter ventilateur			1	
1	6220450	Blæserhus Fan housing Gehäuse für Gebläse Carter ventilateur		1		1
2	6220403	Indsugningstragt Suction funnel Saugtrichter Entonnoir d'aspiration		1	1	1
3	6200458	Oliepumpekonsol Bracket for fuel pump Stützplatte f. Brennstoffpumpe Support pompe à fuel		1	1	1
4	1803956	Taptite skrue Taptite screw Taptite Schraube Vis Taptite	M 4x12	4	4	4
5	6220408	Blæserhjul Impeller Gebläserad Ventilateur		1	1	1
6	3200680	Kugleleje Ball bearing Kugellager Roulement à billes		1	1	1
7	3200995	Feder Key Federkeil Clavette		1	1	1
8	6201405	Remskive Pulley Riemenscheibe Poulie			1	
-	6200468	Remskive Pulley Riemenscheibe Poulie		1		1
9	1800309	Skive Washer Scheibe Rondelle		1	1	1
10	6200436	Møtrik Nut Mutter Ecrou	M 10	1		1
-	1800465	Møtrik Nut Mutter Ecrou	M 10		1	
12	3800984	Kobling Coupling Kupplung Accouplement		1	1	1
13	6220404	Koblingslange Hose f. coupling Schlauch f. Kupplung Tuyau p. accouplement		1	1	1
14	3800992	Kobling Coupling Kupplung Accouplement		1	1	1
15	1801091	Skrue Screw Schraube Vis	M 5x10	1	1	1
16	3821320	Oliepumpe, m. spole Fuel pump, w. coil Danfoss Brennstoffpumpe, m. Spule Pompe à fuel, a. bobine	24 V	1	1	1
-	1119214	Rep.sæt, filter & pakning Rep.kit, filter & gasket Rep.satz, Filter & Dichtung	(Suntec)	x	x	x
-	1119217	Kit de rép., filtre & joint	(Danfoss)	x	x	x

Pos. Ref.	Nr. No.	Betegnels Bezeichnung	Designation Désignation	3803	4203/C3	5003/C3
-	1814045	Møtrik Nut Mutter Ecrou	(Suntec)	1	1	1
-	3820305	Spole Coil Spule Bobine	(Suntec)	1	1	1
-	3821089	Spole, med møtrik og skive Coil, with nut and washer Spule, mit Mutter und Scheibe Bobine, a. écrou + rondelle	(Danfoss)	1	1	1
16	3821321	Oliepumpe, m. spole Fuel pump, w. coil Brennstoffpumpe, m. Spule Pompe à fuel, a. bobine	220V	1	1	1
-	3819919	Spole Coil Spule Bobine	220V	1	1	1
17	1604008	Vinkelforskrøning Threaded connection elbow Winkelverschraubung Raccord fileté, coudé		2	2	2
19	6200409	Afstandsbojsning Spacer bushing Distanzbuchse Baque		1	1	1
20	6201402	Aksel Shaft Welle Arbre		1	1	1
21	1803477	Seegerring Seeger circlip ring Seeger-Ring Anneau		1	1	1
22	6220409	Fladrem Belt 50Hz Riemen Courroie	725x12 mm		1	1
22	6220410	Fladrem Belt 60Hz Riemen Courroie	705x12 mm	1	1	1
23	3201019	Kugleleje Ball bearing Kugellager Roulement à billes		1	1	1
24	3812872	Ledning f. oliepumpe Cable f. fuel pump Leitung f. Brennstoffpumpe Câble p. pompe à fuel			1	1
-	6220207	Remskærm Guard f. belt Schutzplatte f. Riemen Tôle protectrice de la courroie	GB		1	
-	6220208	Remskærm Guard f. belt Schutzplatte f. Riemen Tôle protectrice de la courroie				1

598 73 99 - 00.08

Svømmerhus / Float chamber / Schwimmergehäuse / Bac à flotteur

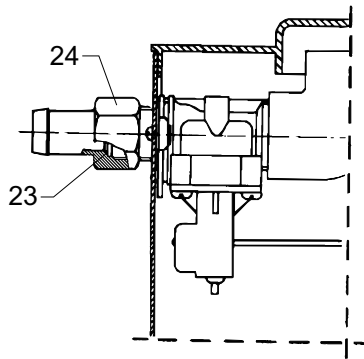
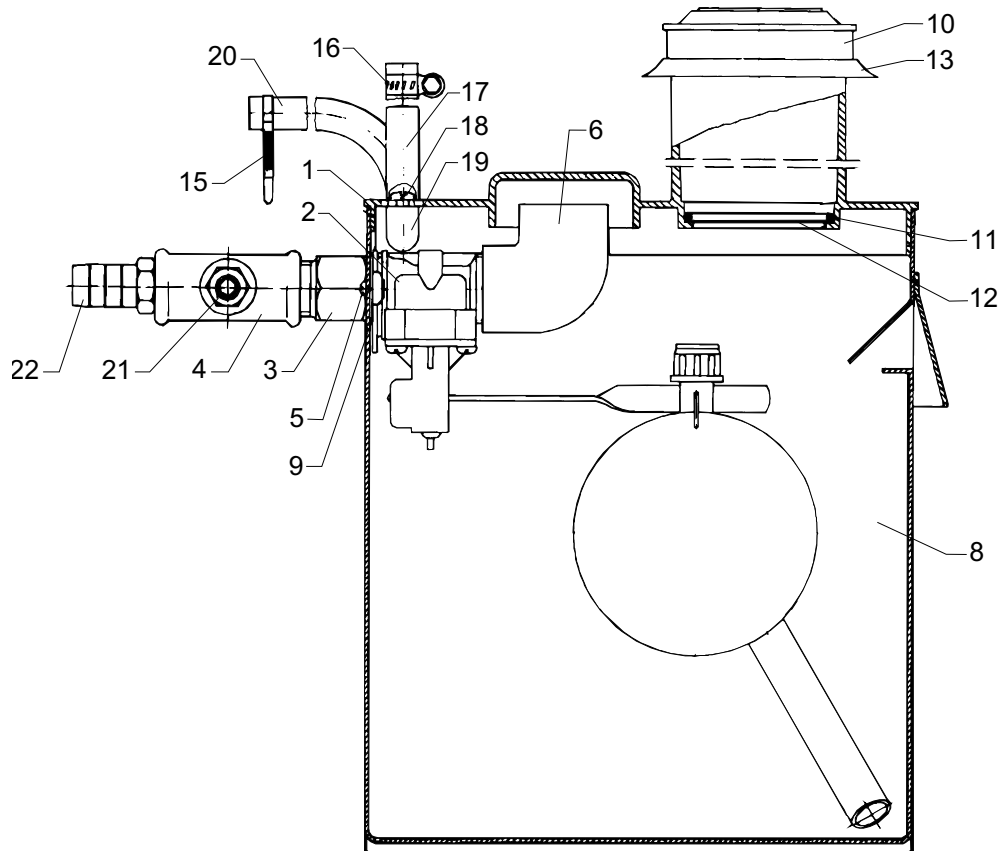

303svh00

Pos. Ref.	Nr. No.	Betegnels Bezeichnung	Designation Désignation	3803	4203/C3	5003/C3
-	-	Svømmerhus, kompl. Float chamber, compl. Schwimmergehäuse, kompl. Bac à flotteur, compl.		x	x	x
1	-	Låg Cover Deckel Couvercle		1	1	1
-	6220600 - 6220601 - 6200630	03V 03VA ⇒ 01.03.88				
-	6220602 - 6220603 - 6200585	03V 03VA ⇒ 01.03.88	AUS AUS AUS			
-	6220604 - 6221577	03V ⇒ 01.03.88	A, B, DK, R, N (4203V) DK, D			
2	1117035	Svømmerventil Float valve Schwimmerventil Clapet anti-retour		1	1	1
3	6402318	Forskrning Threaded connection Verschraubung Raccord fileté	VA		1	1
4	1600923	Forskrning Threaded connection Verschraubung Raccord fileté	VA		1	1
5	1802891	Skrue Screw Schraube Vis		1	1	1
6	1605971	Vinkel Elbow 3/4" Winkel Raccord coudé		1	1	1
8	6200626	Svømmerhus Float chamber Schwimmergehäuse Bac à flotteur		1	1	1
-	6200625	Svømmerhus Float chamber Schwimmergehäuse Bac à flotteur	⇒ 01.03.88	1	1	1
9	3001724	Pakning Gasket Dichtung Joint		1	1	1
10	2201854	Låg Cover Deckel Couvercle		1	1	1
11	6200662	Springring Circlip Klemmring Circlip		1	1	1
12	6200661	Si Strainer Filter Filtre		1	1	1
13	6200590	Manchet Sleeve Manschette Raccord		1	1	1
15	1802347	Kabelbinder Clamp Schelle Collier de serrage	AUS	1	1	1
16	1802107	Spændebånd Hose clip Schelle Collier de serrage	AUS		1	1
17	2402949	Slange (blå) Hose (blue) Schlauch (blau) Flexible (bleu)	AUS		1	1

Pos. Ref.	Nr. No.	Betegnels Bezeichnung	Designation Désignation	3803	4203/C3	5003/C3
18	1804699	Skrue Screw Schraube Vis	AUS		1	1
19	6200545	Dobbelt studs m. dyse Double socket w. nozzle Doppelstutzen m. Düse Raccord double + buse	AUS		1	1
20	6200654	Slange Hose Schlauch Flexible	AUS		1	1
21	1600527	Slangestuds Hose union Schlauchstutzen Raccord du flexible	VA		1	1
22	6300262	Slangestuds Hose union Schlauchstutzen Raccord du flexible	VA		1	1
23	6200575	Slangestuds Hose union Schlauchstutzen Raccord du flexible	V	1	1	1
24	3001435	Pakning Gasket Dichtung Joint	V	1	1	1

Betjeningspanel / Control panel / Armaturen Brett / Tableau de commande

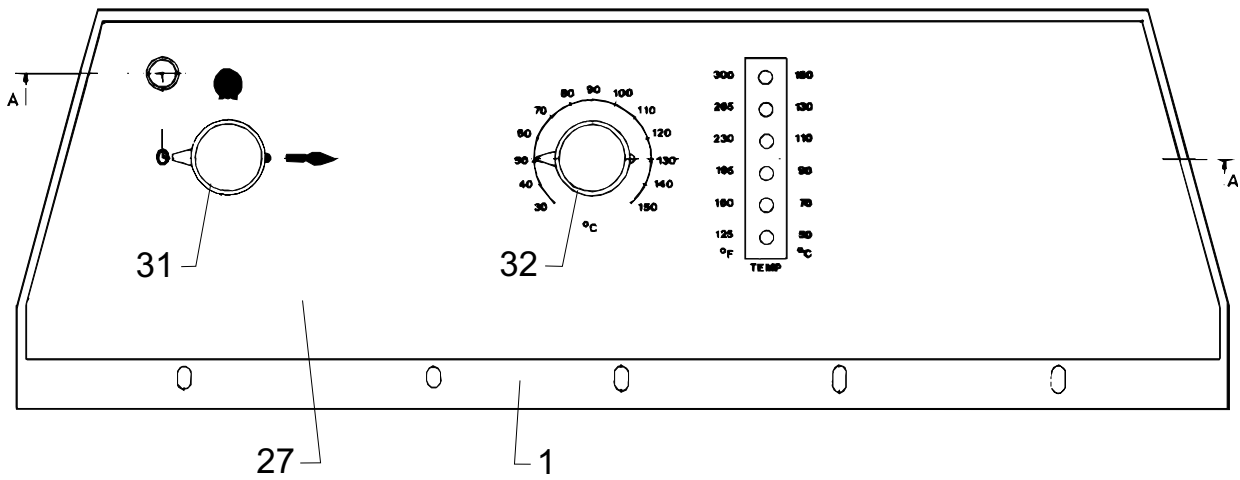
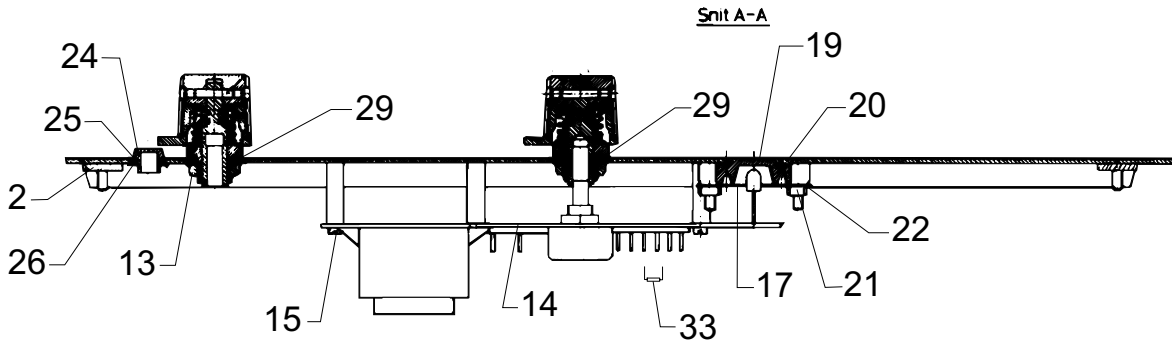

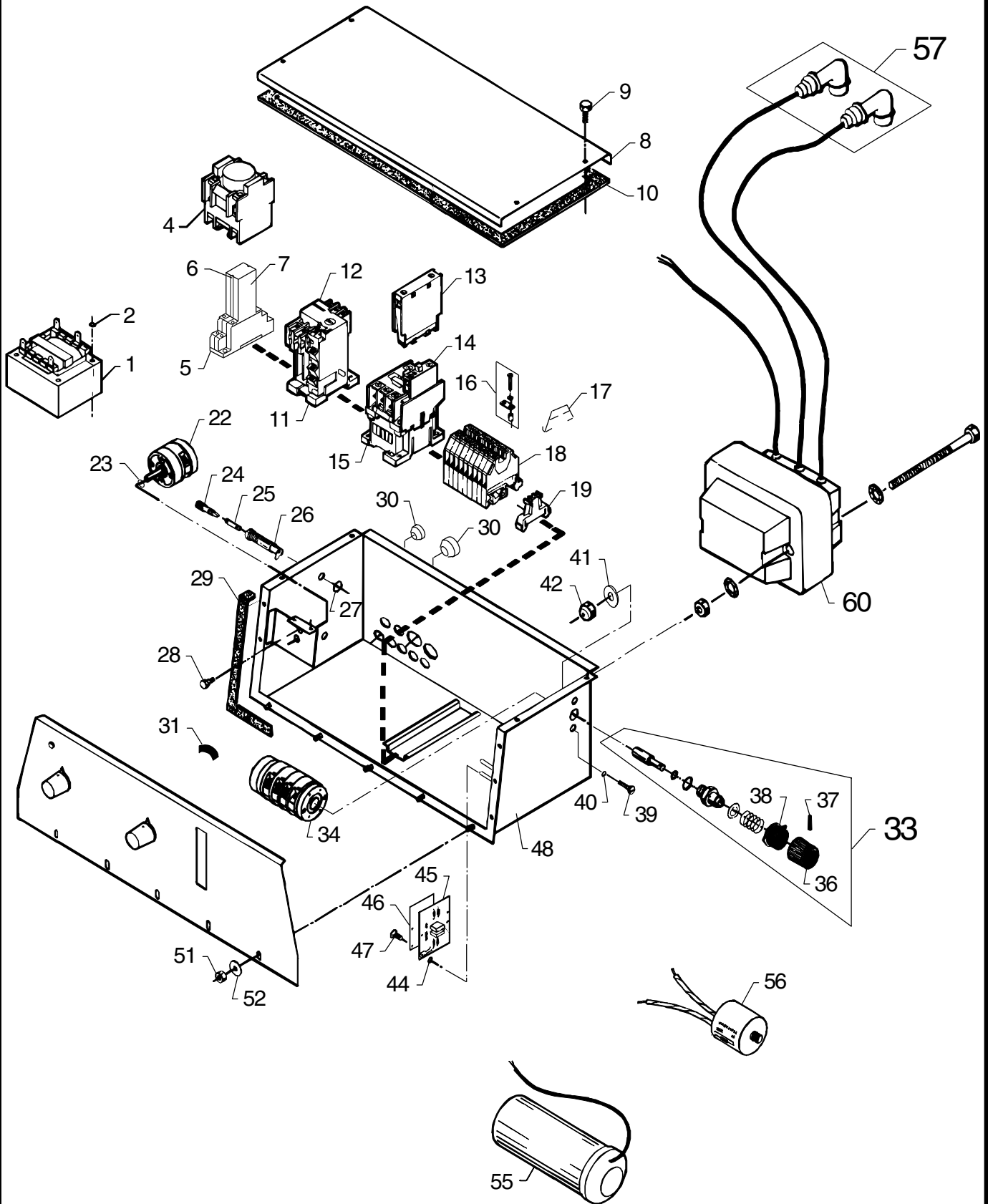

Pos. Ref.	Nr. No.	Betegnels Bezeichnung	Designation Désignation	3803	4203/CS	5003/CS
-	-	Eldele Electrical components Elektrische Komponenten Éléments électriques	01.03.88 =>	x	x	x
1	-	Styrettransformer Control transformer Steuerungstransformator Transformateur de commande	24V	1	1	1
-	3819851	220/380V	I, B, N, SGP			
-	3819786	380V				
-	3819794	427V	GB, AUS			
-	3819760	220V	SJ, CN, ROK, U			
-	3819828	500V	S			
-	3819869	220/440V	(230V60Hz, USA)			
2	1805563	Låseskive Lock washer Federtellerscheibe Disque de blocage		2	2	2
4	3806197	Tidskontakt Switch f. timer Schalter f. Zeitwerk Interrupteur minuterie	Y/Δ			
5	3812633	Relæsokkel Socket for relay Sockel für Relais Socle p. relais		1	1	1
6	3812658	Fjederklemme Terminal point Klemme Borne		2	2	2
7	3812641	Flammerelæ Relay for flame control Relais für Flammenüberwachung Relais pour contrôle flamme		1	1	1
8	6200734	Låg Cover Deckel Couvercle		1	1	1
9	1803956	Skrue Screw Schraube Vis		4	4	4
10	6200744	Pakning Gasket Dichtung Joint		1	1	1
11	3811643	Relæsokkel Socket for relay Sockel für Relais Socle p. relais	SF			
12	3806551	Termorelæ, SF Thermal relay CT 12-17,5A Thermorelais Relais thermique	=> 31.12.99			
12	3821736	Termorelæ, SF Thermal relay 193-EA4GB Thermorelais Relais thermique	01.01.00 =>			
13	3806205	Hjælpekontakt Auxiliary switch, CA3-P-Z01 Hilfsschalter Interrupteur	Y/Δ			
14	3805280	Hjælpekontakt Auxiliary switch, USA Hilfsschalter Interrupteur	=> 31.12.99			
14	3821738	Hjælpekontakt Auxiliary switch, USA Hilfsschalter Interrupteur	01.01.00 =>			

Pos. Ref.	Nr. No.	Betegnels Bezeichnung	Designation Désignation	3803	4203/CS	5003/CS
15	-	Kontaktor Contactor Schütz Contacteur	24V	1	1	1
-	3821404	CA3-16-10	=> 31.12.99			
-	63903	16A 24V 50-60Hz	01.01.00 =>			
-	3804168	CA3-23-10	=> 31.12.99			
-	63907	23A 24V 50-60Hz	01.01.00 =>			
-	3804234	CA3-30-10				
-	3821218	CA3-16-01	CH			
16	3807534	To-polet laske Joint Bipolar Lasche, 2-polig Plaque - bipolaire		2	2	
17	3807542	Klemmeafdækning Cover for terminal-screws Abdeckung f. Anschlußklemmen Couverture barrette à bornes		3	3	3
18	3807518	Rækkeklemme Terminal screw Anschlußklemme Borne		10	10	10
19	3805249	Endeholder Holder Halter Support		1	1	1
22	3810124	Drejekontakt, on/off Rotary switch Drehschalter Interrupteur à rotation		1	1	1
23	3000460	O-ring O-ring O-Ring Joint torique		1	1	1
24	3812666	Sikringsholder Holder f. fuse Halter f. Sicherung Support fusible		1	1	1
25	3808250	Sikring Fuse 1,25 A 250V Sicherung Fusible		1	1	1
26	3812674	Sokkel m. møtrik Socket w. nut Sockel m. Mutter Socle a. écrou		1	1	1
27	3000460	O-ring O-ring O-Ring Joint torique		1	1	1
28	6200802	Skrue Screw Schraube Vis		1	1	1
29	6200745	Pakning Gasket Dichtung Joint		1	1	1
30	-	Gummipakdåse Sealing Stopfbuchse Presse-étoupe				
-	3803764	TET 5-7 C				
-	3803772	TET 7-10 C				
-	3803780	TET 10-14 C				
-	3803798	TET 14-20 C				
31	3821307	Skala f. omskifter Dial f. reverser Skalen f. Umschalter Echelle p. inverseur	220/440V			
31	6101574	Skala f. omskifter Dial f. reverser Skalen f. Umschalter Echelle p. inverseur	220/3800V			
32	3805876	Omskifter, kompl. Switching contact, compl. Umschalter, kompl. Inverseur, compl.	pos.33-40 ref. 33-40 pos. 33-40 ref. 33-40	x	x	x

Eldele / Electric parts / Elektrische Komponenten / Eléments électriques

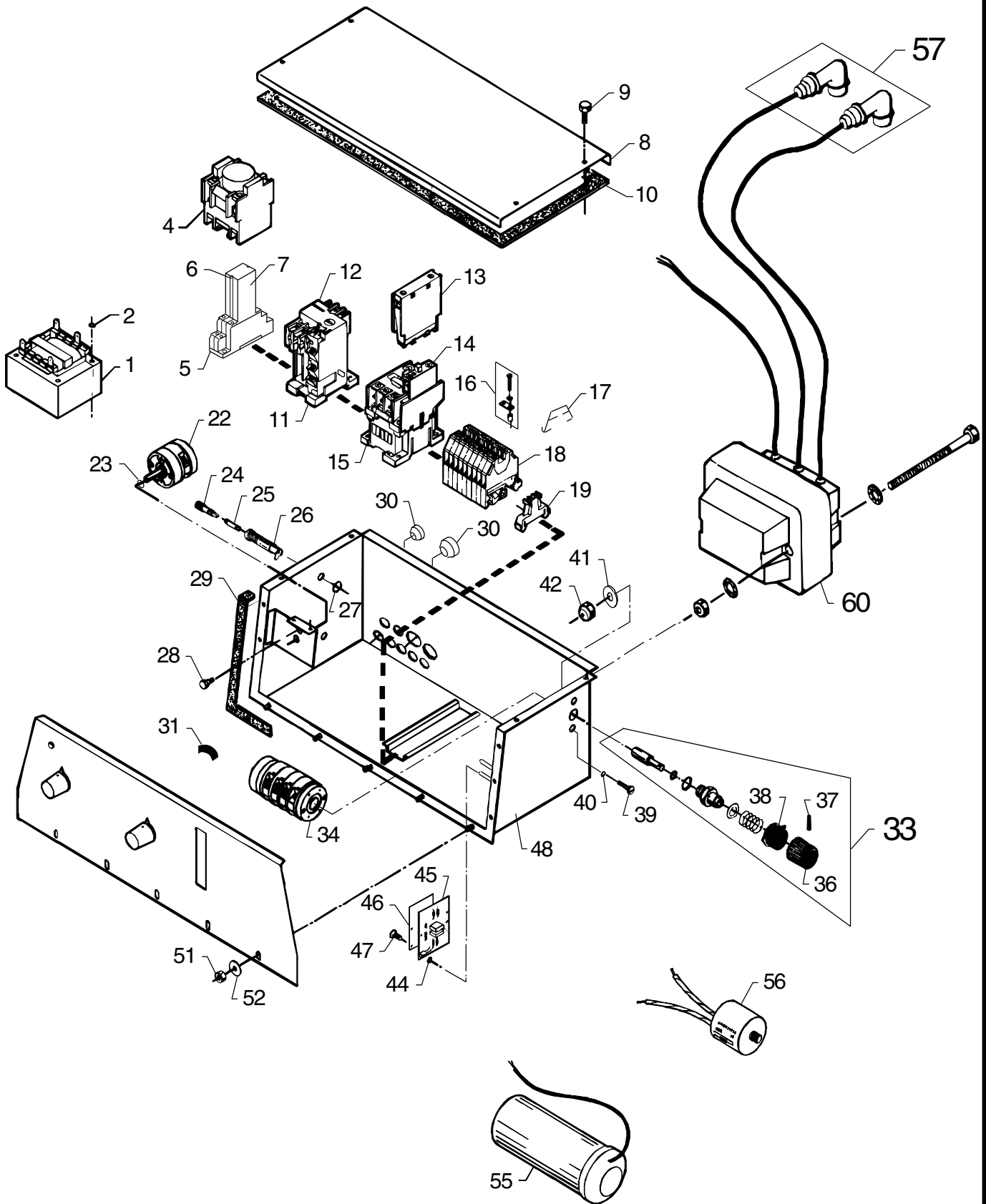

Pos. Ref.	Nr. No.	Betegnels Bezeichnung	Designation Désignation	3803	4203/C3	5003/C3
33	1117357	Knap, kompl. Switch, compl. Schalter, kompl. Interrupteur, compl.		1	1	1
34	3805868	Omskifter Reverser Umschalter Inverseur	Y/Δ	1	1	1
36	4000287	Greb Knob Griff Bouton		1	1	1
37	6100100	Stift Pin Stift Goupille		1	1	1
38	4000303	Viser Indicator Zeiger Indicateur		1	1	1
39	1803451	Skrue Screw Schraube Vis		1	1	1
40	3000387	O-ring O-ring O-Ring Joint torique		1	1	1
41	3000668	Skive Washer Scheibe Rondelle		2	2	2
42	1800457	Møtrik Nut Mutter Ecrou		2	2	2
44	6200750	Skive Washer Scheibe Rondelle		2	2	2
45	6201737	Print Circuit board 220-240V Print Circuit imprimé				
-	6200752	Print Circuit board 380-440V Print Circuit imprimé				
-	6200815	Print Circuit board 480-575V Print Circuit imprimé				
46	6200751	Pap f. print Cardboard f. circuit board Pappe f. Print Carton p. circuit imprimé		1	1	1
47	1803139	Skrue Screw Schraube Vis		2	2	2
48	6201848	El-kasse Connection box Elektrogehäuse Boîtier électrique		1	1	1
-	6201857		CH Y/Δ			
-	6201888		(230V60Hz, USA) Y/Δ			

Pos. Ref.	Nr. No.	Betegnels Bezeichnung	Designation Désignation	3803	4203/C3	5003/C3
51	1800697	Møtrik Nut Mutter Ecrou		12	12	12
52	1800887	Skive Washer Scheibe Rondelle		12	12	12
55	3805371	Kondensator Capacitor Kondensator Condensateur	80 µf 400 VDB			
56	3817202	Jorddrosselspole Radio interfer. suppressor Schutzleiterdrossel Conducteur de protection	CH			
57	1119302	Rep.sæt, tændrørshætte Rep. kit, cover for sparking plug Rep. satz, Deckel für Zündkerzen Kit de rép., capuchon d'électrode		1	1	1
60	-	Tændtransformer Ignition transformer Zündtransformator Transformateur d'allumage		1	1	1
-	3812567	3x415-440V	AUS,GB,NZ,SGP,USA, Off-shore, U,M			
-	3812559	3x380V	A,AR,CL,D,DK,F,HK,IL,NL P,PE,S,SE,ET,GR			
-	3812542	3x220V	I,B,N,E,CN,ROK,SGP SJ,U,USA			
-	3812591	3x380V	CH			
-	3812575	3x500V	S			
-	-	Tilgangskabel Electric cable Anschlußkabel Câble électrique				
	6200863	H05VV-F 4G 1,5	B,E,I,N,HK	x	x	
	6200866	H05VV-F 4G 2,5	CN,ROK	x	x	
	6200867	H07RN-F 4G 2,5	U(5003V/VA), J	x	x	
	6200869	SVCT-F 5G 1,5				
	6180260	H07RN-F 4G 1.5		x	x	
	6180261	H07RN-F 3G 1.5			x	
	6180268	H07RN-F3G4		x		
-	-	Stik Plug Stecker Prise		1	1	1
-	3802493	CEE 5 pol. 380V/16A				
-	3805793	1 pol.	Eur.			
	3802477	S				