

**COMMO**



# **VISPA 35B**

**Ed.01/2007**

**Codice 422304  
N° doc. 10005143**



## CATALOGO RICAMBI

### INTRODUZIONE

Il presente vuole essere da guida per l'ordinazione delle parti di ricambio ed è stato realizzato in modo da consentire una rapida identificazione della macchina in tutte le sue versioni e quindi una rapida visualizzazione dei pezzi che la compongono.

### MODALITA' DI ORDINAZIONE

Per facilitare la ricerca di magazzino e la spedizione dei pezzi di ricambio, si pregano vivamente i Sigg. Clienti di attenersi alle seguenti norme e specificare sempre :

- a) modello e numero di matricola della macchina;
- b) numero di posizione e numero di tavola dove sono rappresentati;
- c) codice di ordinazione e denominazione;
- d) quantità dei pezzi desiderati;
- e) indirizzo esatto e ragione sociale del Committente, completo con l'eventuale recapito per la consegna della merce;
- f) mezzo di spedizione desiderato. (Nel caso questa voce non sia specificata la Ditta Costruttrice si riserva di usare a sua discrezione il mezzo più opportuno).

## SPARE PARTS CATALOGUE

### INTRODUCTION

This catalogue is intended to serve as a guide for the ordering of spare parts and is designed to facilitate rapid identification of the machine in all its versions and to rapid location of its component parts.

### HOW TO ORDER

For the purpose of simplifying stock searching and the delivery of spare parts, we would ask our customers to observe the following standard procedures, at all times specifying:

- a) the model and part number of the machine;
- b) the position number and the number of the table of chart in which the parts appear;
- c) ordering code and part name;
- d) quantity of parts required;
- e) precise address and company status of the purchaser placing the order, complete with address for delivery of the goods;
- f) shipping means required.

## CATALOGUE DES PIECES DE RECHANGE

### INTRODUCTION

Le présent catalogue a pour but de guider l'utilisateur dans les commandes de pièces détachées. Il a été réalisé pour faciliter une identification rapide de la machine dans toutes ses versions et permet ainsi un repérage rapide de ses composants.

### COMMENT PASSER COMMANDE

Afin de simplifier la recherche dans le magasin et l'expédition des pièces de rechange, nous prions notre clientèle de respecter la procédure suivante en indiquant toujours:

- a) le modèle et numéro de la machine;
- b) le numéro de la position et numéro du tableau sur lequel figure la pièce;
- c) la référence et la dénomination;
- d) la quantité des pièces demandées;
- e) l'adresse exacte et la raison sociale de l'acheteur qui passe la commande, en indiquant l'adresse de livraison;
- f) le moyen de transport désiré (dans le cas où ceci n'est pas précisé l'expéditeur se réserve le droit de choisir le transporteur).

## ERSATZTEILKATALOG

### EINLEITUNG

Der vorliegende Katalog versteht sich als Führer für Ersatzteile und soll eine rasche Identifikation der Maschine in all ihren Ausführungen ermöglichen und daher ein sofortiges Erkennen der Teile, aus denen sie besteht.

### BESTELLVORSCHLAG

Um ein Auffinden im Lager und den Versand der Ersatzteile zu erleichtern, werden die Kunden ersucht, sich an folgende Normen zu halten und immer folgendes anzugeben:

- a) Modell- und Gerätenummer;
- b) Positions- und Tafelnummer, wo sie dargestellt sind;
- c) Bestellnummer und Handelsbezeichnung;
- d) Menge der gewünschten Teile;
- e) Genaue Adresse und Firmennamen des Auftraggebers, gemeinsam der ev. Anschrift für die Zusendung der Ware;
- f) Die gewünschte Versandart (falls nicht angegeben, behält sich der Lieferant das Recht vor, die günstigste Art zu wählen).

## CATALOGO PIEZAS DE REPUESTO

### INTRODUCCIÓN

Ese catálogo quiere servir cómo guía para pedir las piezas de repuesto y se ha realizado de manera de consentir una rápida identificación de la máquina en todas sus versiones y por consiguiente una rápida individuación de las piezas que la componen.

### MODALIDADES DE LOS PEDIDOS

Para la búsqueda en el almacén y el envío de las piezas de repuesto, se ruega encarecidamente a los Sres. Clientes de seguir las reglas siguientes y de especificar siempre:

- a) el modelo y el número de matrícula de la máquina;
- b) el número de posición y el número de la tabla donde son representadas;
- c) el código de pedido y la denominación;
- d) el número de piezas que se desean;
- e) las señas exactas y la razón social del Comitente, indicando también las señas eventuales para la entrega de la mercancía;
- f) El medio de envío que se desea. (En caso de que ese dato no se haya especificado, la Empresa Constructora se reserva el derecho de utilizar a su elección el medio más adecuado.

### SIMBOLOGIA USATA NEL CATALOGO

SYMBOLGY USED IN THE CATALOGUE

SIMBOLE DANS LE CATALOGUE

SIMBOLGEBRAUCH IM KATALOG

SIMBOLOGIA EMPLEADA EN EL CATALOGO

→ I XXXXXXXX

Codice utilizzato fino alla matricola indicata  
Code used up to the indicated serial number  
Code utilisé jusqu'au numéro indiqué  
Artikel benutzt bis zur angegebenen Nummer  
Código utilizado hasta el número indicado

XXXXXXX I →

Codice utilizzato dalla matricola indicata  
Code used from the indicated serial number  
Code utilisé a partir du numéro indiqué  
Artikel benutzt ab angegebenen Nummer  
Código utilizado desde el número indicado



## SOMMARIO

### SUMMARY / SOMMAIRE / INHALTSANGABE / ÍNDICE

- TAV. 01**      **GRUPPO BASAMENTO SPAZZOLE**  
SINGLE BRUSH BASE ASSEMBLY / GROUPE PLATEAU DES BROSSES / GRUPPE BÜRSTENGESTELL / GRUPO BANCADA CEPILLO
- TAV. 02**      **GRUPPO TELAIO**  
FRAME ASSEMBLY / GROUPE DE CHASSIS / GRUPPE RAHMEN / GRUPO BASTIDOR
- TAV. 03**      **GRUPPO SERBATOI - ACCESSORI**  
TANKS ASSEMBLY - ACCESSORIES / GROUPE DE RESERVOIRS - ACCESSOIRES / GRUPPE TANKS - ZUBEHURTEILE / GRUPO TANQUES - ACCESORIOS
- TAV. 04**      **GRUPPO TERGIPAVIMENTO**  
SQUEEGEE ASSEMBLY / ENSEMBLE DE SUCEUR / SAUGFUSSGRUPPE / GRUPO LIMPIADORES DE SUELO
- TAV. 05**      **GRUPPO COMANDO TERGIPAVIMENTO**  
SQUEEGEE CONTROL ASSEMBLY / GROUPE COMMANDE DE SUCEUR / SAUGFUSSBETÄTIGUNG / MANDO LIMPIAPAVIMENTOS
- TAV. 06**      **GRUPPO MANUBRIO**  
HANDLE BAR ASSEMBLY / GROUPE DE TIMON / FUHRUNGSHOLMGRUPPE / GRUPO MANILAR
- TAV. 07**      **GRUPPO IMPIANTO ELETTRICO**  
ELECTRONICAL CONTROL ASSEMBLY / ENSEMBLE COMMANDE ELECTR. / ELEKRONISCHE ANLAGE / GRUPO CONTROLES ELECTR.
- TAV. 08**      **ACCESSORI**  
ACCESSORIES / ACCESSOIRES / ZUBEHORTEILE / ACCESORIOS
-



# GRUPPO BASAMENTO VISPA

01

POS.	CODICE	QTA	DESCRIZIONE	DENOMINATION	DESCRIPTION	BENENNUNG	DESCRIPCION
1	202475	1	MOLLA TRAZIONE 17,5X2,5X69	SPRING	RESSORT	FEDER	RESORTE
2	204329	3	DISTANZIALE ATTACCO SPAZZOLA	SPACER	ENTRETOISE	DISTANZHUELSE	DISTANCIADOR
3	206829	1	FLANGIA DI ATTACCO SPAZZOLA	FLANGE	FLASQUE	FLANSCH	BRIDA
4	212363	1	DISTANZIALE D=30 d=20,2 S=6 C40	SPACER	ENTRETOISE	DISTANZHÜLSE	DISTANCIADOR
5	212364	1	BOCCOLA PER TENDICINGHIA	BUSHING	BAGUE	BUCHSE	CASQUILLO
6	212365	1	DISTANZIALE D=30 d=21 S=2 C40	SPACER	ENTRETOISE	DISTANZHÜLSE	DISTANCIADOR
7	212375	1	FLANGIA PULEGGIA	FLANGE	FLASQUE	FLANSCH	BRIDA
8	212413	1	PERNO FLANGIA BAS.	PIN	AXE	BOLZEN	PERNO
9	213120	1	SUPPORTO INF. BASAMENTO	SUPPORT	SUPPORT	HALTERUNG	SOPORTE
10	213121	1	SUPPORTO SUP. BASAMENTO	SUPPORT	SUPPORT	HALTERUNG	SOPORTE
11	213122	1	TENDICINGHIA	TIGHTENER	TENDEUR	SPANNER	TENDEDOR
12	213170	1	PULEGGIA LISCIA D=200 VISPA	PULLEY	POULIE	RIEMENSCHIEBE	PULEA
13	213391	1	TUBO VITREO 5x30	PIPE	TUBE	ROHR	TUBO
14	407663	4	VITE M6x16 TE UNI 5739 ZINC	SCREW	VIS	SCHRAUBE	TORNILLO
15	408420	3	CUSCINETTO A SFERE 6001-2RS1	BEARING	ROULEMENT	LAGER	COJINETE
16	408435	2	CUSCINETTO SF 6204 D=47 d=20 S=14	BEARING	ROULEMENT	LAGER	COJINETE
17	408636	2	VITE M4X25 TE UNI 5739 INOX A2	SCREW	VIS	SCHRAUBE	TORNILLO
18	408674	1	VITE M8x25 TE UNI 5739 ZINC	SCREW	VIS	SCHRAUBE	TORNILLO
19	408983	3	VITE M8x40 TPSEI UNI 5933 ZINC	SCREW	VIS	SCHRAUBE	TORNILLO
20	408986	1	VITE M8x25 TPSEI UNI5933 ZINC	SCREW	VIS	SCHRAUBE	TORNILLO
21	409079	2	DADO M4x6 AUTOBL. UNI 7473 A2	NUT	ECROU	MUTTER	TUERCA
22	409082	1	DADO M6x6 AUTOBL UNI 7474 ZINC	LOCK NUT	ECROU AUTOFREINES	SICHERUNGSMUTTER	TUERCA AUTOBLOCANTE
23	409085	4	DADO M8x8.5 AUTOBL. UNI 7474 ZINC	LOCK NUT	ECROU AUTOFREINES	SICHERUNGSMUTTER	TUERCA AUTOBLOCANTE
24	409143	2	ROSETTA 4X9X0,8 UNI 6592 A2	WASHER	RONDELLE	UNTERLEGSCHIEBE	ARANDELA
25	409150	2	ROSETTA 5X11X1 UNI 6592 ZINC	WASHER	RONDELLE	UNTERLAGSCHIEBE	ARANDELA
26	409156	1	ROSETTA 6x12x1,6 UNI 6592 ZINC	WASHER	RONDELLE	UNTERLAGSCHIEBE	ARANDELA
27	409175	1	ROSETTA 8x17x1,6 UNI 6592 ZINC.	WASHER	RONDELLE	UNTERLAGSCHIEBE	ARANDELA
28	409212	1	RONDELLA D14 UNI 6592 INOX	WASHER	RONDELLE	UNTERLAGSCHIEBE	ARANDELA
29	409236	3	SPESSORE RAM 15x22x0,3 DIN 988 ZINC	SHIM	EPAISSEUR	BEILAGERING	ARANDELA ESPESOR
30	409328	1	SPESSORE RAM 37x47x0,3 DIN 998	SHIM	EPAISSEUR	BEILAGERING	ARANDELA ESPESOR
31	409831	1	TAPPO SALVAFILETTO DIAM.11.5	COVER	COUVERCLE	DECKEL	TAPA
32	410443	1	DADO 1/4" GAS	NUT	ECROU	MUTTER	TUERCA
33	411964	1	VITE 6X16 UNI 5933 ZINC. TSPEI	SCREW	VIS	SCHRAUBE	TORNILLO
34	415783	3	VITE M4X10 TCTC UNI 7687 INOX A2	SCREW	VIS	SCHRAUBE	TORNILLO
35	416431	2	VITE M5x14 TE UNI 5739 ZINC	SCREW	VIS	SCHRAUBE	TORNILLO
36	416781	2	DADO M5X5 AUTOBL. UNI 7473 ZINC	LOCK NUT	ECROU AUTOFREINES	SICHERUNGSMUTTER	TUERCA AUTOBLOCANTE
37	420605	1	MOTORE 12V 250W 1500G 30A IP20	MOTOR	MOTEUR	MOTOR	MOTOR
38	420647	1	SUPPORTO ELETTROVALVOLA	SUPPORT	SUPPORT	HALTERUNG	SOPORTE
39	421111	1	CINGHIA POLY V J6 - 303	BELT	COURROIE	RIEMEN	CORREA
40	421121	1	ELETTROVALVOLA 12V CC D150PS75/3/300	SOLENOID VALVE	ELECTROVANNE	MAGNETVENTIL	ELETTROVALVULA
41	421576	1	TUBO DISTRIBUTORE	PIPE	TUBE	ROHR	TUBO
42	421664	1	PARASPRUZZI VISPA	SPLASH GUARD	BAVETTE DE PROTECTION	SPRITZGUMMI	PARASALPICADURAS
43	421983	3	FONDELLO FILETTATO M4 A 4 PUNTE	INSERT	ENCART	EINSATZ	INSERTO

# GRUPPO BASAMENTO VISPA

SINGLE BRUSH BASE ASSEMBLY

GRUPE PLATEUS DES BROSSES

GRUPPE BURSTENGESTELL

GRUPO BANCADA CEPILLO

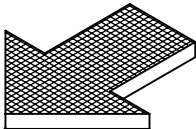
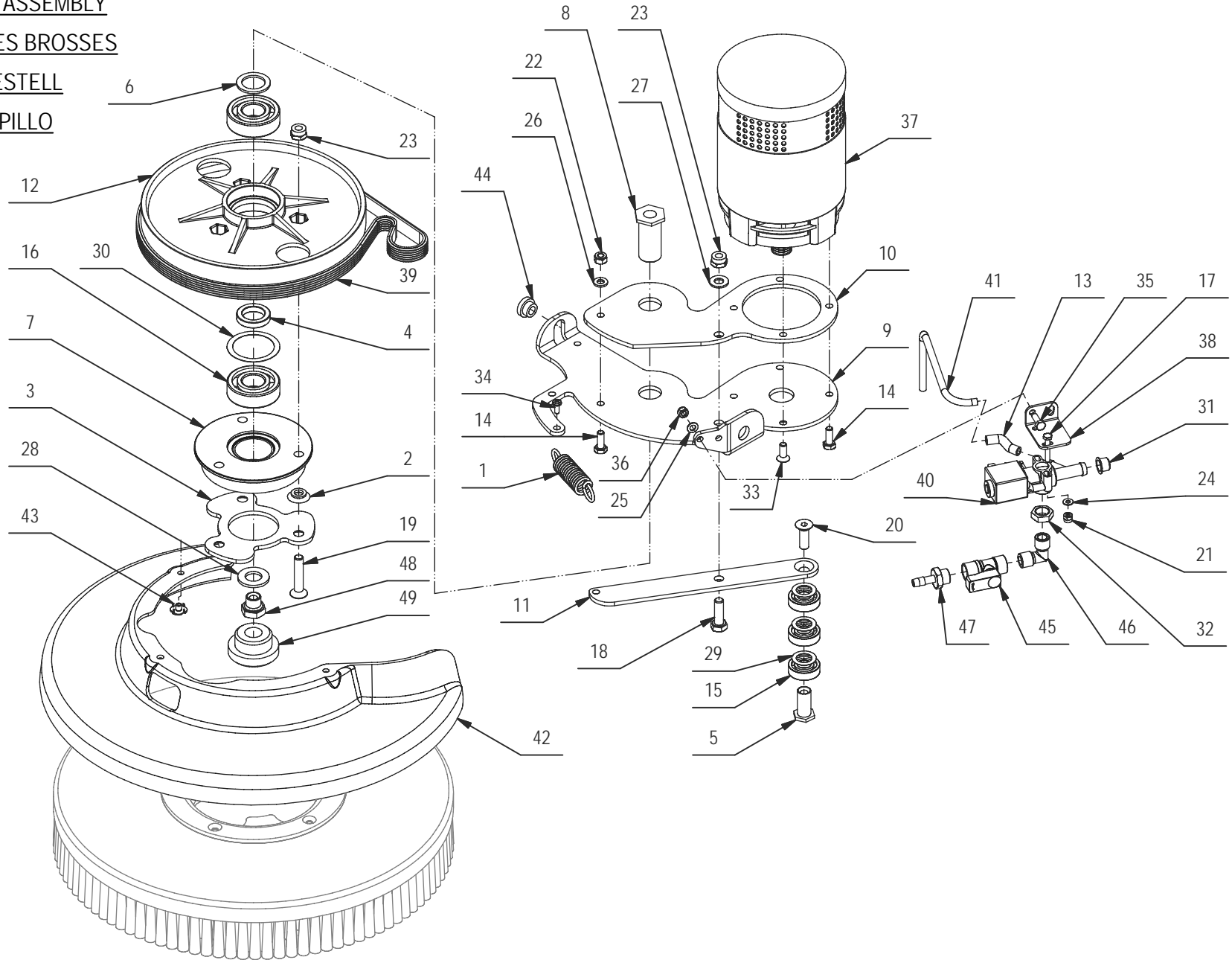

**GRUPPO BASAMENTO VISPA****01**

POS.	CODICE	QTA	DESCRIZIONE	DENOMINATION	DESCRIPTION	BENENNUNG	DESCRIPCION
44	422120	2	BOCCOLA D=18-13 d=8 S=9,5 OT54	BUSHING	BAGUE	BUCHSE	CASQUILLO
45	422183	1	RUBINETTO 1/4 F-F L= 38 C.LEVA	COCK	ROBINET	WASSERHAHN	GRIFO
46	422184	1	RACC. A GOMITO 1/4 M.M. OTT. NICH.	ELBOW	COUDE	WINKELVERSCHRAUBUNG	RACOR CODO
47	422186	1	RACC. PORTAGOMMA 1/4x7 OTT. NICH.	FITTING	RACCORD	VERSCHRAUBUNG	RACOR
48	422187	1	TAPPO M 1/4 CON FORO D.7,3 ZINCATO	COVER	COUVERCLE	DECKEL	TAPA
49	422206	1	BOCCOLA IN NYLON VISPA	BUSHING	BAGUE	BUCHSE	CASQUILLO

# GRUPPO TELAIO VISPA

ASSEMBLY FRAME

GROUPE DE CHASSIS

GRUPPE RAHMEN

GRUPO BASTIDOR

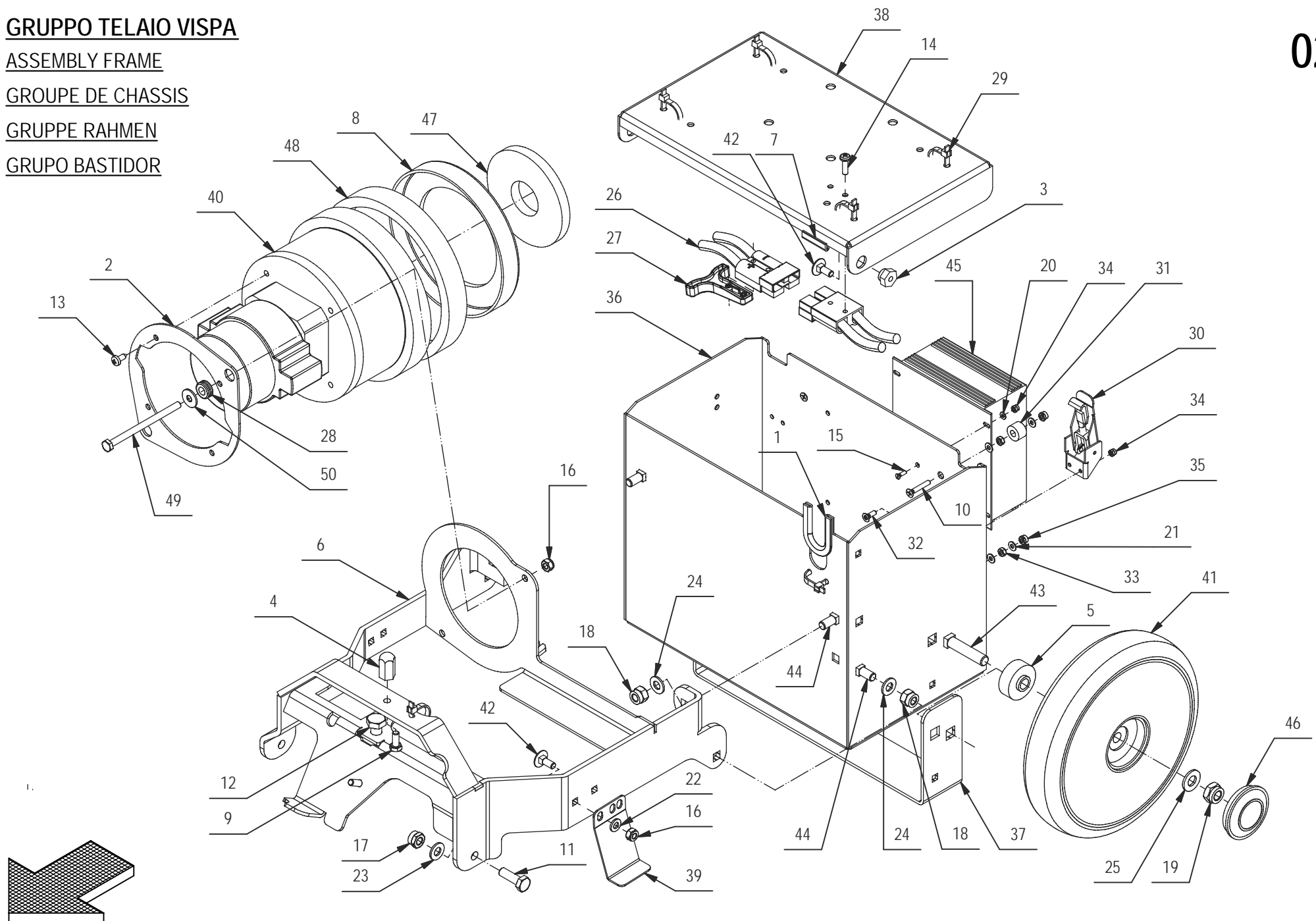

POS.	CODICE	QTÀ	DESCRIZIONE	DENOMINATION	DESCRIPTION	BENENNUNG	DESCRIPCION
1	213323	1	PROFILO GOMMA A -U- 8,5X6 L=110	PROFILE	PROFIL	PROFIL	PERFIL
2	204233	1	PIASTRA MOTORE	PLAQUE	PLAQUE	BEFESTIGUNGSAUFLAGE	PLACA
3	212368	2	BOCCOLA CH15 M6 S=10 OT58	BUSHING	BAGUE	BUCHSE	CASQUILLO
4	212373	1	PERNO CENTRAGGIO SERBATOIO	PIN	AXE	BOLZEN	PERNO
5	212412	2	BOCCOLA D=35 d=10.5 S=15,5 OT58	BUSHING	BAGUE	BUCHSE	CASQUILLO
6	212445	1	TELAIO VISPA	FRAME	CHASSIS	RAHMEN	BASTIDOR
7	213322	1	PROFILO GOMMA A -U- 8,5X6 L=30	PROFILE	PROFIL	PROFIL	PERFIL
8	405936	1	CUFFIA MOTORE ASPIRAZIONE 60.037	SHROUD SUCTION MOTOR	JOINT MOTEUR D'ASPIRATION	LAGERRING SAUGMOTOR	ANILLO MOTOR DE ASPIRACION
9	407661	1	VITE M6x14 TE UNI 5739 ZINC	SCREW	VIS	SCHRAUBE	TORNILLO
10	408510	2	VITE M4X25 TSPTC UNI 7688 (4.8) ZINC.	SCREW	VIS	SCHRAUBE	TORNILLO
11	408674	2	VITE M8x25 TE UNI 5739 ZINC	SCREW	VIS	SCHRAUBE	TORNILLO
12	408708	1	VITE M10X16 TE UNI 5739 ZINC	SCREW	VIS	SCHRAUBE	TORNILLO
13	408883	4	VITE D.4,8x13 TCTC AUTOF. NICH UNI 6954	SCREW	VIS	SCHRAUBE	TORNILLO
14	408893	2	VITE D.5x17 AUTOF. POLI LOCK SPUNTATA	SCREW	VIS	SCHRAUBE	TORNILLO
15	408922	8	VITE M3x10 TPS UNI 6109 A2	SCREW	VIS	SCHRAUBE	TORNILLO
16	409082	6	DADO M6x6 AUTOBL UNI 7474 ZINC	LOCK NUT	ECROU AUTOFREINES	SICHERUNGSMUTTER	TUERCA AUTOBLOCANTE
17	409085	2	DADO M8x8.5 AUTOBL. UNI 7474 ZINC	LOCK NUT	ECROU AUTOFREINES	SICHERUNGSMUTTER	TUERCA AUTOBLOCANTE
18	409087	4	DADO M8x10.5 AUTOBL. UNI 7474 A2	LOCK NUT	ECROU AUTOFREINES	SICHERUNGSMUTTER	TUERCA AUTOBLOCANTE
19	409091	2	DADO M10x10 AUTOBL. UNI 7474 A2	LOCK NUT	ECROU AUTOBLOQUANT	STOPMUTTER	TUERCA AUTOBLOCANTE
20	409138	4	ROSETTA 3X7X0,5 INOX UNI 6592 A2	WASHER	RONDELLE	UNTERLAGSCHEIBE	ARANDELA
21	409142	8	ROSETTA 4x9x0,8 UNI 6592 ZINC	WASHER	RONDELLE	UNTERLAGSCHEIBE	ARANDELA
22	409156	4	ROSETTA 6x12x1,6 UNI 6592 ZINC	WASHER	RONDELLE	UNTERLAGSCHEIBE	ARANDELA
23	409175	2	ROSETTA 8x17x1,6 UNI 6592 ZINC.	WASHER	RONDELLE	UNTERLAGSCHEIBE	ARANDELA
24	409177	4	ROSETTA 8x17x1,6 UNI 6592 A2	WASHER	RONDELLE	SCHEIBE	ARANDELA
25	409192	2	ROSETTA 10x21x2 UNI 6592 A2	WASHER	RONDELLE	UNTERLAGSCHEIBE	ARANDELA
26	409666	2	CONNETTORE 50A 600V	CONNECTOR	CONNECTEUR	STECKER	CONECTOR
27	409683	1	MANIGLIA PER CONNETTORE 50A	HANDLE	MANCHE	HANDGRIFF	MANILLA
28	409810	2	PASSAFILO DIAM. 8x12x1.5	FAIRLEAD	PASSE-CABLE	KABELDURCHGANG	GUIACABLE
29	410277	6	FASCETTA IN PLASTICA 4,8X200	CLAMP	COLLIER	BRIDE	ABRAZADERA
30	410329	2	GANCIO CASSETTO	HOOK	CROCHET	HAKEN	GANCHO
31	414688	2	DISTANZIALE D=15 d=6.5 S=10 PVC	SPACER	ENTRETOISE	DISTANZHÜLSE	DISTANCIADOR
32	415793	2	VITE M4X12 TPSTC UNI 7688 (4.8) ZINC	SCREW	VIS	SCHRAUBE	TORNILLO
33	415884	4	DADO M4 UNI 5588 INOX	NUT	ECROU	MUTTER	TUERCA
34	415897	8	DADO M3 AUTOBL. UNI7474 A2	LOCK NUT	ECROU AUTOBLOCANT	STOPMUTTER	TUERCA AUTOBLOCANTE
35	415898	4	DADO M4 AUTOBL UNI7474	LOCK NUT	ECROU AUTOBLOQUANT	STOPMUTTER	TUERCA AUTOBLOCANTE
36	420585	1	VANO BATTERIA VISPA	BATTERY BASE	BAC LOGEMENT BATTERIES	BATTERIEKASTEN	PLACA ASIEN TO BATERIAS
37	420599	1	RINFORZO VANO BATTERIA	PLAQUE	PLAQUE	BEFESTIGUNGSAUFLAGE	PLACA
38	420601	1	COPERCHIO VANO BATTERIA	COVER	COUVERCLE	DECKEL	TAPA
39	420603	2	PIASTRA SOSTEGNO SERBATOIO	PLAQUE	PLAQUE	BEFESTIGUNGSAUFLAGE	PLACA
40	420672	1	MOTORE ASPIRAZIONE 24V - 500W	SUCTION MOTOR	MOTEUR D'ASPIRATION	SAUGMOTOR	MOTOR DE ASPIRACION
41	420674	2	RUOTA RES 200X42	WHEEL 200X42	ROUE 200X42	RAD 200X42	MUEDA 200X42
42	421080	6	VITE M6X16 TTQST (UNI 5732 DIN 603) INOX	SCREW	VIS	SCHRAUBE	TORNILLO
43	421082	2	VITE M10X50 TTQST (UNI 5732 DIN 603)INOX	SCREW	VIS	SCHRAUBE	TORNILLO

# GRUPPO TELAIO VISPA

ASSEMBLY FRAME

GRUPE DE CHASSIS

GRUPPE RAHMEN

GRUPO BASTIDOR

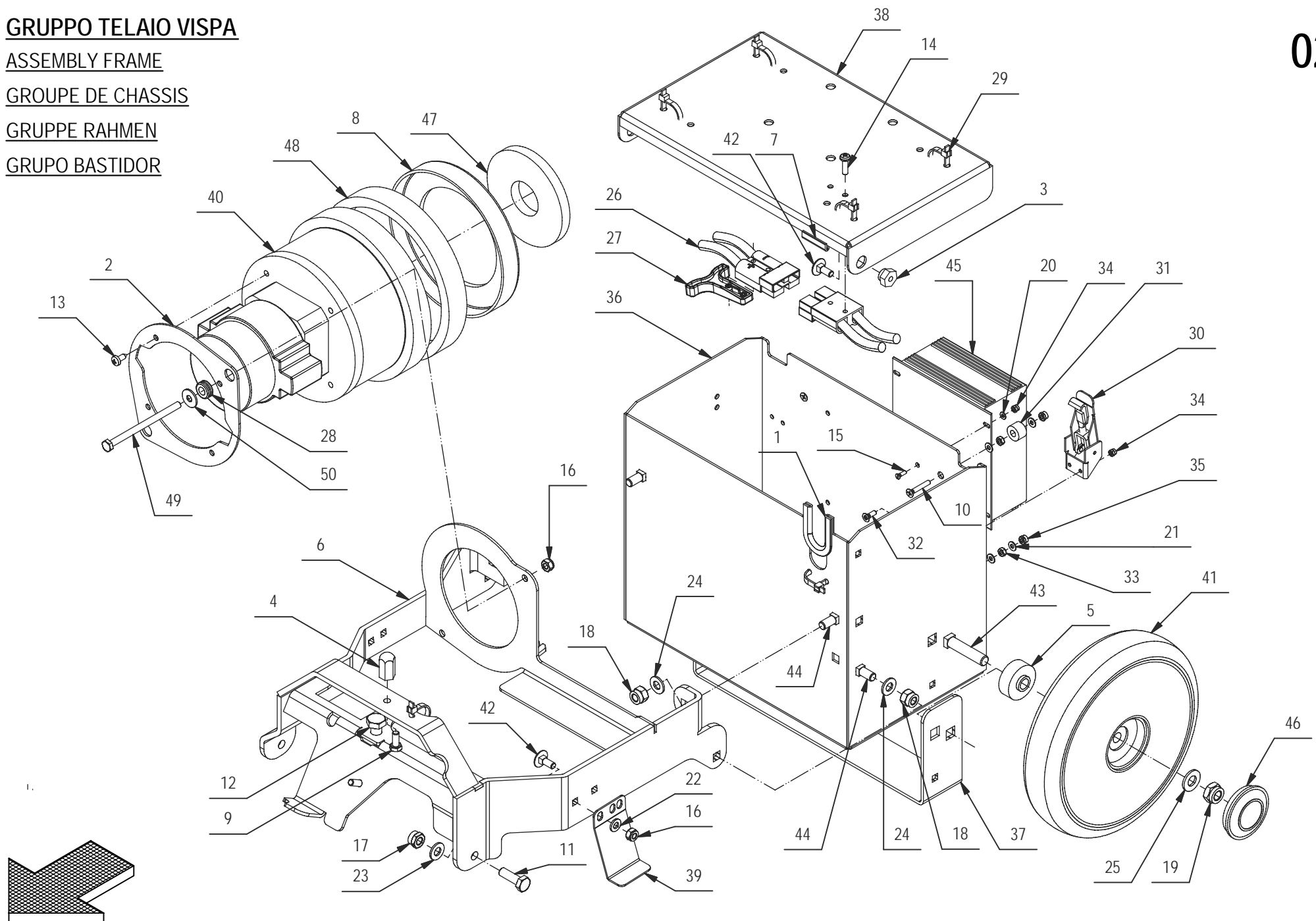

**GRUPPO TELAIO VISPA****02**

POS.	CODICE	QTÀ	DESCRIZIONE	DENOMINATION	DESCRIPTION	BENENNUNG	DESCRIPCION
44	421083	4	VITE M8X20 TTQST (UNI 5732 DIN 603) INOX	SCREW	VIS	SCHRAUBE	TORNILLO
45	421671	1	CARICABATT. SPE CBHD1 12V6A IUUO GEL	BATTERY CHARGER	CARGHEUR	BATTERIE LADEGERATE	CARGADOR DE BATERIAS
46	421675	2	TAPPO COPRIMOZZO G48 RUOTA VISPA	COVER	COUVERCLE	DECKEL	TAPA
47	421767	1	FONOASSORBENTE ADESIVO H10	DEADENING	ISOLANT PHONIQUE	SCHALLDICHTUNG	FONOABSORBENTE
48	421811	2	FONOASSORBENTE ADESIVO H10x460x23	DEADENING	ISOLANT PHONIQUE	SCHALLDICHTUNG	FONOABSORBENTE
49	422078	2	VITE M6X90 TE UNI5737 DIN931 ZINC	SCREW	VIS	SCHRAUBE	TORNILLO
50	409160	2	ROSETTA 6x18x1,5 UNI 6593 ZINC	WASHER	RONDELLE	UNTERLAGSCHEIBE	ARANDELA

**GRUPPO SERBATOI - ACCESSORI VISPA**

ASSEMBLY TANKS - ACCESSORIES

GRUPE DE RESERVOIRS - ACCESSOIRES

GRUPPE TANKS - ZUBEHURTEILE

GRUPO TANQUES - ACCESORIOS

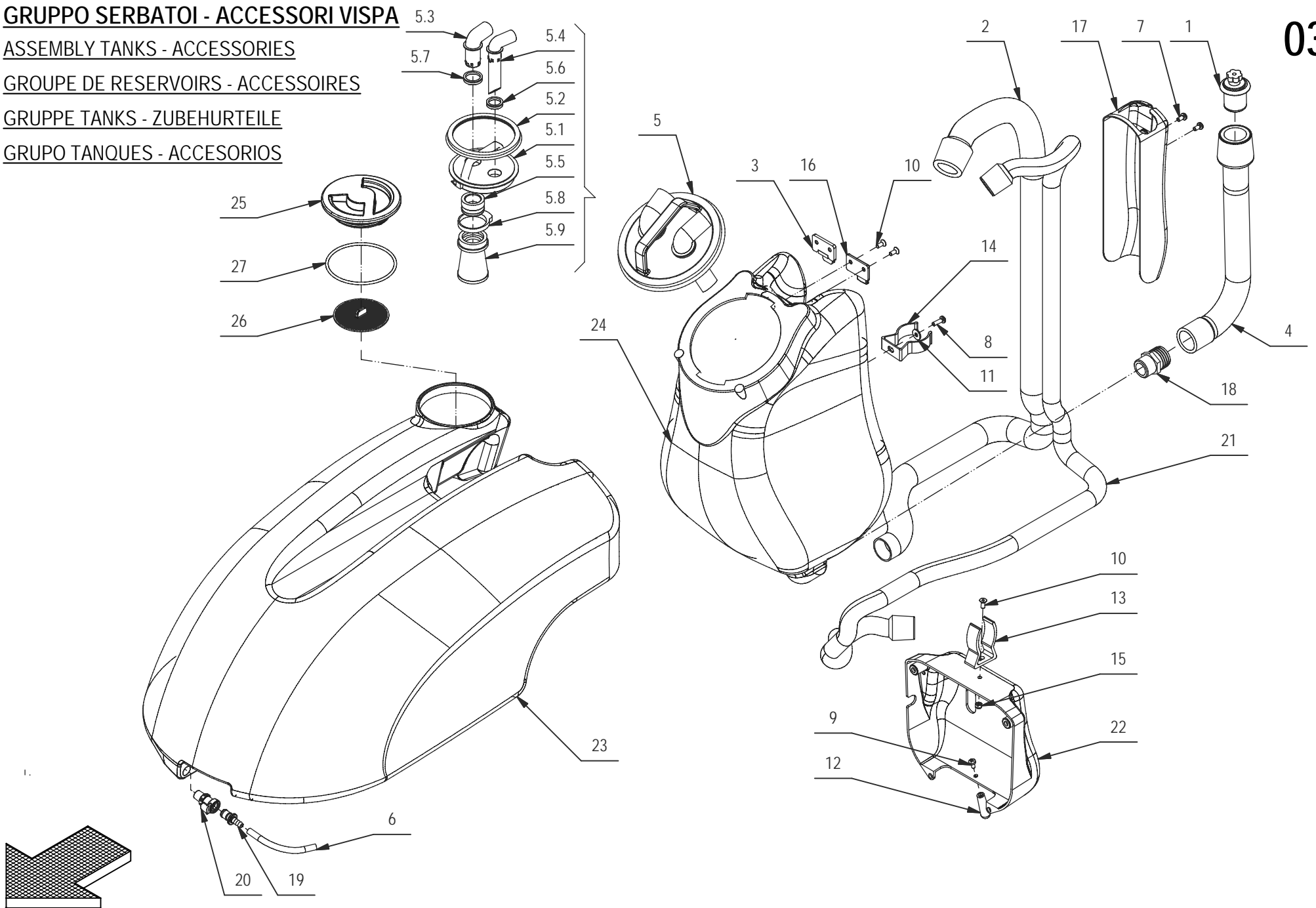

# GRUPPO SERBATOI - ACCESSORI VISPA

03

POS.	CODICE	QTÀ	DESCRIZIONE	DENOMINATION	DESCRIPTION	BENENNUNG	DESCRIPCION
1	204356	1	TAPPO SCARICO SENZA FASCETTA	PLUG EXHAUST PIPE	BOUCHON DE VIDANGE	ABLASSPFROPFEN	TAPON DE DESCARGA
2	213041	1	TUBO ASP. D.29X1250 CON MANICOTTO	SUCTION HOSE	FLEXIBLE ASPIRATION	SAUGSCHLAUCH	TUBO DE ASPIRACION
3	213132	2	GANCIO SALDATO VISPA	HOOK	CROCHET	HAKEN	GANCHO
4	213150	1	TUBO SCARICO	EXHAUST PIPE	FLEXIBLE DE VIDANGE	ABWASSERSCHLAUCH	TUBO DE DESCARGA
5	213190	1	PREMONTAGGIO TAPPO SERB. RECUPERO	CAP	CAPUCHON	KAPPE	TAPON
5.1	420604	1	TAPPO SERBATOIO RECUPERO	CAP	CAPUCHON	KAPPE	TAPON
5.2	405466	1	GUARNIZIONE FILTRO SERBATOIO	GASKET	JOINT	DICHTUNG	JUNTA
5.3	420606	1	RACCORDO TUBO ASPIRAZIONE	FITTING	RACCORD	VERSCHRAUBUNG	RACOR
5.4	420607	1	RACCORDO TUBO RECUPERO	FITTING	RACCORD	VERSCHRAUBUNG	RACOR
5.5	212372	1	SUPPORTO FILTRO	SUPPORT	SUPPORT	HALTERUNG	SOPORTE
5.6	416771	1	GUARNIZIONE V-RING VA25 H=7,5 NBR	V-RING	JOINT	V-RING	JUNTA ANULAR
5.7	421109	1	GUARNIZIONE V-RING VA30 H=7,5 NBR	V-RING	JOINT	V-RING	JUNTA ANULAR
5.8	411988	1	FASCETTA A SCATTO	CLAMP	COLLIER	BRIDE	ABRAZADERA
5.9	421662	1	ASSIEME FILTRO CONICO	FILTER ASSEMBLY	FILTRE COMPLET	FILTER KOMPLETT	FILTRO COMPLETO
6	213251	1	TUBO DIAM.8x5 L105 VITREO	PIPE	TUBE	ROHR	TUBO
7	408848	4	VITE M5X10 TCTC UNI 7687 A2	SCREW	VIS	SCHRAUBE	TORNILLO
8	408854	1	VITE M5X16 TCTC UNI EN ISO 704	SCREW	VIS	SCHRAUBE	TORNILLO
9	408883	1	VITE D.4,8x13 TCTC AUTOF. NICH UNI 6954	SCREW	VIS	SCHRAUBE	TORNILLO
10	408963	5	VITE M5x12 TPSEI UNI5933 A2	SCREW	VIS	SCHRAUBE	TORNILLO
11	409151	1	ROSETTA 5x15x1.5 UNI 6593 ZINC	WASHER	RONDELLE	UNTERLAGSCHEIBE	ARANDELA
12	410264	1	MANOPOLA COMMUTATORE	KNOB COMMUT.	POIGNEE COMM.	HANDGRIFF SCHALT.	EMPUÑADURA CONM.
13	412123	1	CLIP ABS FISSAGGIO TUBO D.38	SPRING	RESSORT	FEDER	RESORTE
14	412123	1	CLIP ABS FISSAGGIO TUBO D.38	SPRING	RESSORT	FEDER	RESORTE
15	416781	1	DADO M5X5 AUTOBL. UNI 7473 ZINC	LOCK NUT	ECROU AUTOFREINES	SICHERUNGSMUTTER	TUERCA AUTOBLOCANTE
16	420609	2	GANCIO SERBATOIO	HOOK	CROCHET	HAKEN	GANCHO
17	420673	1	CARTER COPRI TUBI	COVER	CARTER	ABDECKUNG	CARTER
18	421680	1	RACCORDO PORTAGOMMA 3/4x30	FITTING	RACCORD	VERSCHRAUBUNG	RACOR
19	421743	1	INNESTO: PORTAGOMMA CPC APC22004	MALE COUPLING	EMBAYAGE MALE	KUPPLUNG MIT ZAPFEN	ACOPLAMIENTO MACHO
20	421744	1	INNESTO: RACCORDO CPC APC10004BSP	FEMALE COUPLING	EMBAYAGE FEMELLE	KUPPLUNG OHNE ZAPFEN	ACOPLAMIENTO HEMBRA
21	421746	1	TUBO REC. D.20x1600 CON MANIC. VISP	PIPE	TUBE	ROHR	TUBO
22	421830	1	CARTER CARICABATTERIA TERM. VISPA	COVER	CARTER	ABDECKUNG	CARTER
23	421933	1	SERBATOIO SOLUZIONE VISPA	SOLUTION TANK	RESERVOIR EAU PROPRE	FRISCHWASSERTANK	TANQUE SOLUCION
24	421935	1	SERBATOIO RECUPERO VISPA	RECOVERY TANK	RESERVOIR EAU SALE	SCHMUTZWASSERTANK	TANQUE AGUA SUCIA
25	422004	1	TAPPO FILETTATO LOGO COMAC VISPA	CAP	CAPUCHON	KAPPE	TAPON
26	422034	1	FILTRO D.75 SERB.SOL.VISPA	FILTER	FILTRE	FILTER	FILTRO
27	422064	1	GUARNIZIONE OR 4350 d=3,53 D=88,50	O-RING	JOINT	O-RING	JUNTA ANULAR

# GRUPPO TERGIPAVIMENTO VISPA

SQUEEGEE ASSEMBLY

ENSEMBLE DE SUCEUR

SAUGFUSSGRUPPE

GRUPO LIMPIADORES DE SUELO

04

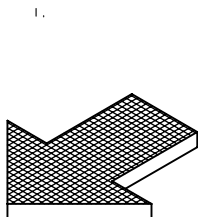
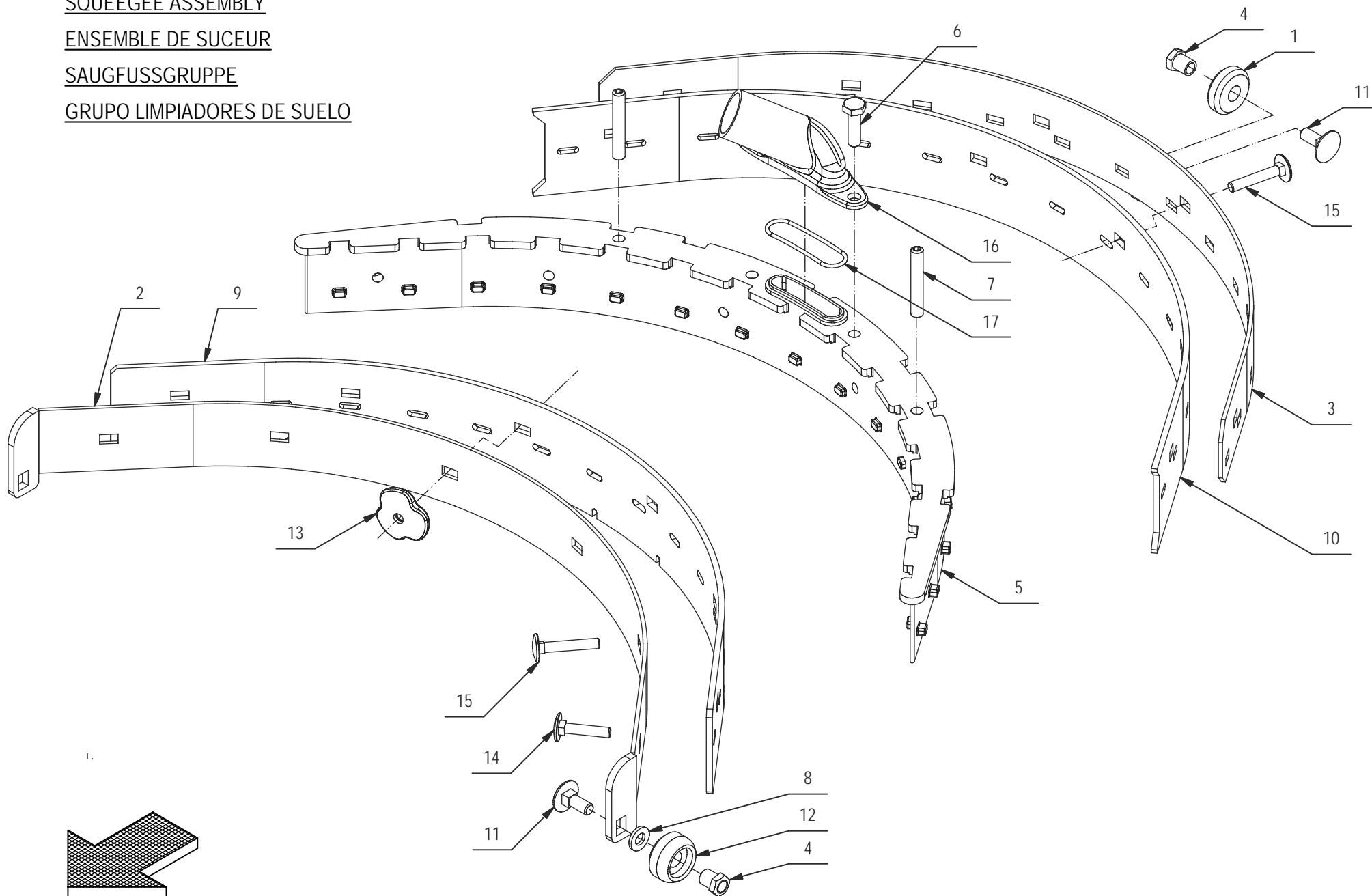

**GRUPPO TERGIPAVIMENTO VISPA****04**

POS.	CODICE	QTÀ	DESCRIZIONE	DENOMINATION	DESCRIPTION	BENENNUNG	DESCRIPCION
1	212933	1	RUOTINA TERGIPAVIMENTO	WHEEL	ROUE	RAD	RUEDA
2	212934	1	PREMIGOMMA ANTERIORE	BLADE	PLAQUETTE	LEISTE	LISTON
3	212935	1	PREMIGOMMA POST. SALDATA	BLADE	PLAQUETTE	LEISTE	LISTON
4	212936	3	BOCCOLA RUOTINA TERGI	BUSHING	BAGUE	BUCHSE	CASQUILLO
5	213231	1	TERGI IN FUSIONE VISPA	SQUEEGEE BODY	CORPS DE SUCEUR	SAUGFUSSKÖRPER	CUERPO LIMPIAPAVIMENTOS
6	407667	2	VITE M6X20 TE UNI 5739 A2	SCREW	VIS	SCHRAUBE	TORNILLO
7	408905	2	GRANO M6x40 EI UNI5923 A2	DOWEL	VIS CYLINDRIQUE	MADENSCHRAUBE	TORNILLO
8	409157	2	ROSETTA 6x12x1,6 INOX UNI 6592	WASHER	RONDELLE	UNTERLEGSCHIEBE	ARANDELA
9	420648	1	GOMMA TERGI ANTERIORE	FRONT RUBBER	BAVETTE AVANT	VORDERER SAUGGUMMI	GOMA DELANTERA
10	420649	1	GOMMA TERGI POSTERIORE	REAR RUBBER	BAVETTE ARRIERE	HINTERER SAUGGUMMI	GOMA TRASERA
11	421080	3	VITE M6X16 TTQST (UNI 5732 DIN 603) INOX	SCREW	VIS	SCHRAUBE	TORNILLO
12	421101	2	RUOTINA TERGI D.24 d.8.2 VISPA	WHEEL	ROUE	RAD	RUEDA
13	421733	6	GALLETTO PLASTICO	WING NUT	PAPILLON	FLÜGELSCHRAUBE	POMO
14	421930	2	VITE M5x25 TTQST UNI 5732 INOX	SCREW	VIS	SCHRAUBE	TORNILLO
15	421931	4	VITE M5x30 TTQST UNI 5732 INOX	SCREW	VIS	SCHRAUBE	TORNILLO
16	422112	1	BOCCHETTA TERGI	OPENING	BUSE	ÖFFNUNG	BOQUILLA
17	422113	1	GUARNIZIONE OR 2131 - D.1,78X33,05	O-RING	JOINT	O-RING	JUNTA ANULAR

**GRUPPO COMANDO TERGIPAVIMENTO VISPA**

SQUEEGEE CONTROL ASSEMBLY

COMMANDE DE SUCEUR

SAUGFUSSBETAETIGUNG

MANDO LIMPIAPAVIMENTOS

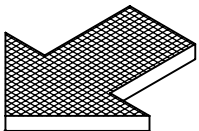
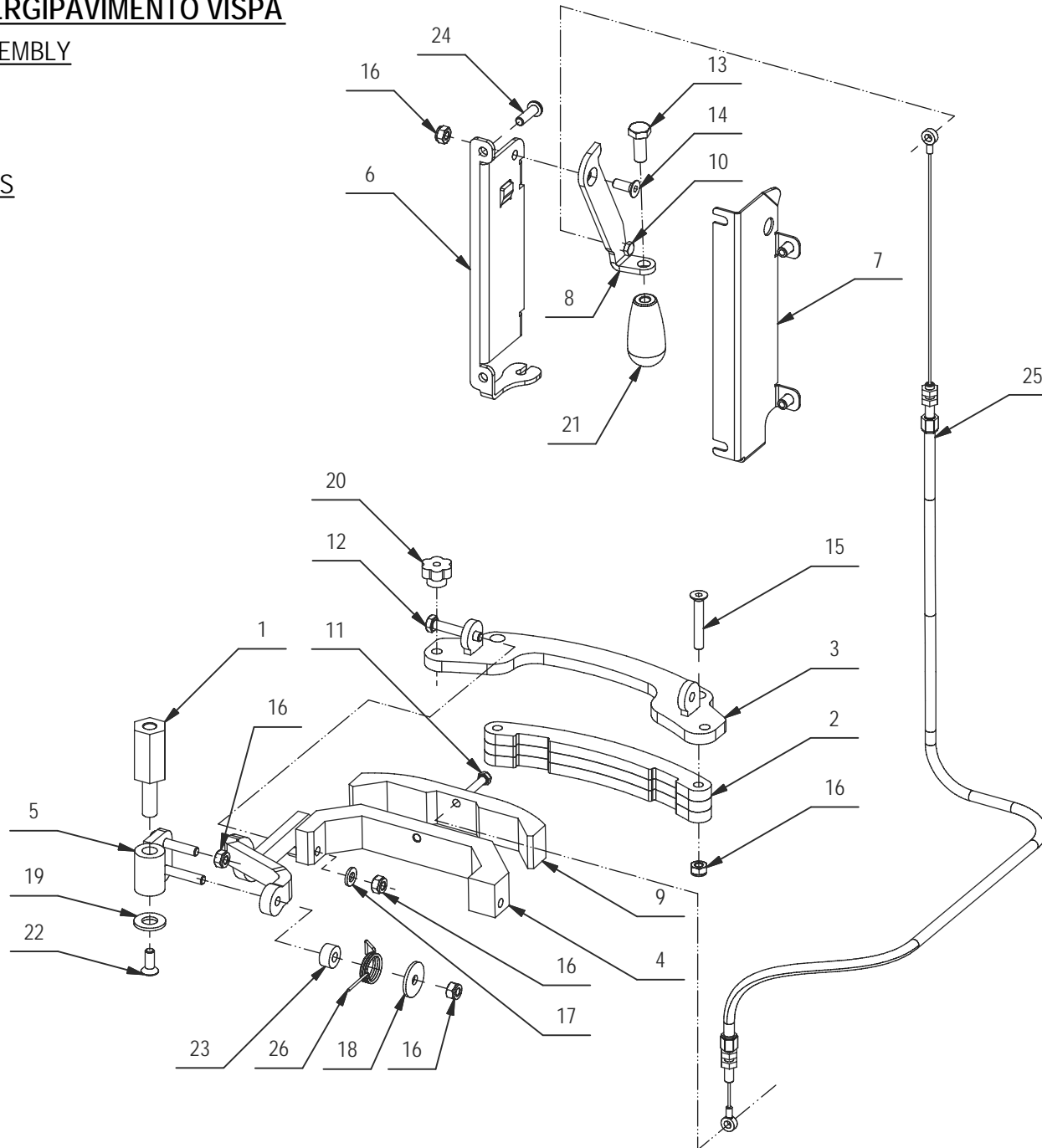

# GRUPPO COMANDO TERGIPAVIMENTO VISPA

05

POS.	CODICE	QTÀ	DESCRIZIONE	DENOMINATION	DESCRIPTION	BENENNUNG	DESCRIPCION
1	212411	1	BOCCOLA CH20 OT58	BUSHING	BAGUE	BUCHSE	CASQUILLO
2	213126	3	ZAVORRA TERGIPAVIMENTO	BALLAST	LEST	BALLAST	LASTRE
3	213127	1	SUPPORTO TERGI	SUPPORT	SUPPORT	HALTERUNG	SOPORTE
4	213128	1	COMANDO TERGI	ARM	BRAS	ARM	BRAZO
5	213129	1	SUPPORTO COMANDO TERGI	SUPPORT	SUPPORT	HALTERUNG	SOPORTE
6	213220	1	SUPPORTO DX LEVA COMANDO TERGI	RIGHT SUPPORT	SUPPORT DROITE	RECHTE HALTERUNG	SOPORTE DERECHO
7	213221	1	SUPPORTO SX LEVA COMANDO TERGI	LEFT SUPPORT	SUPPORT GAUCHE	HALTERUNG LINKS	SOPORTE IZQUIERDO
8	213222	1	LEVA COMANDO TERGI	LEVER	LEVIER	HEBEL	PALANCA
9	213223	1	PESO AGGIUNTIVO TERGI VISPA	BALLAST	LEST	BALLAST	LASTRE
10	407643	1	VITE M5X8 TE UNI 5739 ZINC	SCREW	VIS	SCHRAUBE	TORNILLO
11	407651	1	VITE M5X25 TE UNI 5739 DIN 933 (8.8)ZINC	SCREW	VIS	SCHRAUBE	TORNILLO
12	408651	2	VITE M6x35 TE UNI 5739 ZINC	SCREW	VIS	SCHRAUBE	TORNILLO
13	408670	1	VITE M8x20 TE UNI 5739 ZINC	SCREW	VIS	SCHRAUBE	TORNILLO
14	408966	1	VITE M6x16 TPSEI UNI 5933 ZINC	SCREW	VIS	SCHRAUBE	TORNILLO
15	408971	2	VITE M6x40 TPSEI UNI 5933 FP ZINC	SCREW	VIS	SCHRAUBE	TORNILLO
16	409082	7	DADO M6x6 AUTOBL UNI 7474 ZINC	LOCK NUT	ECROU AUTOFREINES	SICHERUNGSMUTTER	TUERCA AUTOBLOCANTE
17	409156	2	ROSETTA 6x12x1,6 UNI 6592 ZINC	WASHER	RONDELLE	UNTERLAGSCHEIBE	ARANDELA
18	409162	1	ROSETTA 6,5x24x2 UNI 6593 ZINC	WASHER	RONDELLE	UNTERLAGSCHEIBE	ARANDELA
19	409192	1	ROSETTA 10x21x2 UNI 6592 A2	WASHER	RONDELLE	UNTERLAGSCHEIBE	ARANDELA
20	410225	2	POMELLO VB20 - D.20 M6 F.P.	KNOB	POMMEAU	KUGELGRIF	POMO
21	410265	1	MANOPOLA CILINDRICA MC/23x55 M8	KNOB	POIGNEE	HANDGRIFF	EMPUÑADURA
22	411964	1	VITE 6X16 UNI 5933 ZINC. TSPEI	SCREW	VIS	SCHRAUBE	TORNILLO
23	414689	1	DISTANZIALE D=15 d=6,5 S=7,5 PVC	SPACER	ENTRETOISE	DISTANZHÜLSE	DISTANCIADOR
24	415855	2	VITE TBEI M6X20 ISO 7380	SCREW	VIS	SCHRAUBE	TORNILLO
25	420695	1	CAVO SOLLEVAMENTO TERGI	CABLE	CABLE	KABEL	CUERDA
26	421730	1	MOLLA A TORSIONE	SPRING	RESSORT	FEDER	RESORTE

# GRUPPO MANUBRIO VISPA

HANDLE BAR ASSEMBLY

GROUPE DE TIMON

FUHRUNGSHOLMGRUPPE

GRUPO MANILLAR

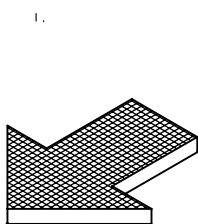
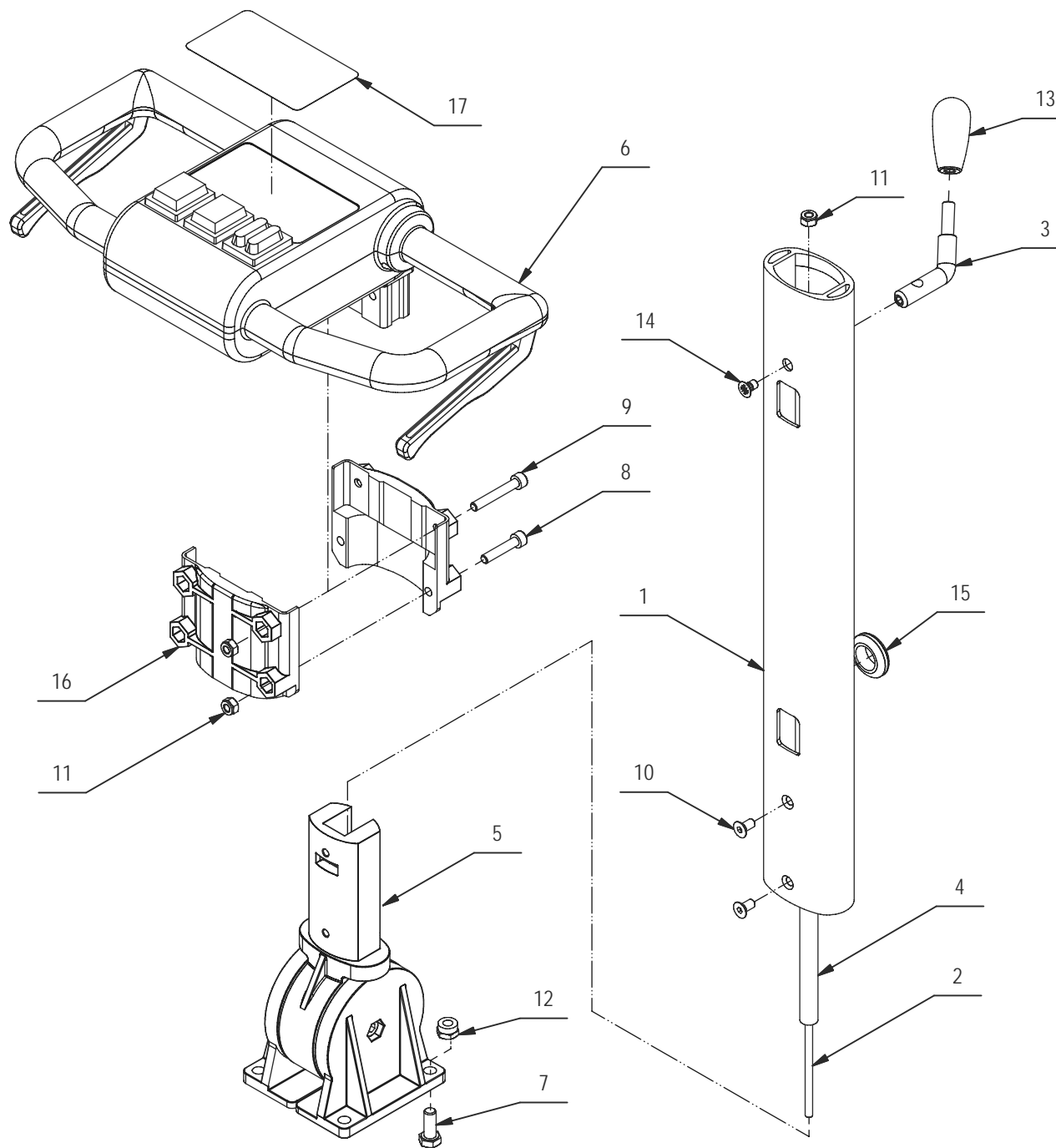

## GRUPPO MANUBRIO VISPA

06

POS.	CODICE	QTÀ	DESCRIZIONE	DENOMINATION	DESCRIPTION	BENENNUNG	DESCRIPCION
1	212367	1	TUBO MANUBRIO VISPA	ROD	TIGE	STANGE	VARILLA
2	212369	1	BARRA FILETTATA M6 L=448	TIE ROD	TIGE	SPANNSTANGE	TIRANTE
3	212370	1	PERNO SGANCIO MANUBRIO	PIN	AXE	BOLZEN	PERNO
4	212371	1	TUBO VITREO 8X2X340	PIPE	TUBE	ROHR	TUBO
5	213171	1	SNODO MANUBRIO SENZA FINE CORSA	JOINT	JOINT	GELENK	ARTICULACION
6	213184	1	PREM. MANUBRIO VISPA	STEERING WHEEL ASSEMBLY	VOLANT COMPLET	LENKRAD KOMPLETT	VOLANTE COMPLETO
7	408670	4	VITE M8x20 TE UNI 5739 ZINC	SCREW	VIS	SCHRAUBE	TORNILLO
8	408798	2	VITE M6x30 TCEI UNI 5931 ZINC	SCREW	VIS	SCHRAUBE	TORNILLO
9	408802	2	VITE M6X40 TCEI UNI 5931 FP ZINC	SCREW	VIS	SCHRAUBE	TORNILLO
10	408965	2	VITE M6X12 TPSEI UNI5933 ZINC	SCREW	VIS	SCHRAUBE	TORNILLO
11	409082	5	DADO M6x6 AUTOBL UNI 7474 ZINC	LOCK NUT	ECROU AUTOFREINES	SICHERUNGSMUTTER	TUERCA AUTOBLOCANTE
12	409085	4	DADO M8x8.5 AUTOBL. UNI 7474 ZINC	LOCK NUT	ECROU AUTOFREINES	SICHERUNGSMUTTER	TUERCA AUTOBLOCANTE
13	410265	1	MANOPOLA CILINDRICA MC/23x55 M8	KNOB	POIGNEE	HANDGRIFF	EMPUÑADURA
14	415805	1	VITE 6X10 UNI 7688 ZINC. TSPTC	SCREW	VIS	SCHRAUBE	TORNILLO
15	416820	1	PASSACAVO PER FORO D.25 Di=15	FAIRLEAD	PASSE-CABLE	KABELDURCHGANG	GUIACABLE
16	420608	2	STAFFA MANUBRIO	SUPPORT	ATTAQUE	HALTERUNG	SOPORTE FIJADOR
17	421731	1	ETICHETTA CRUSCOTTO VISPA 35B	DECAL	ETIQUETTE	SCHILD	ETIQUETA

**GRUPPO MANUBRIO VISPA**

HANDLE BAR ASSEMBLY

GROUPE DE TIMON

FUHRUNGSHOLMGUPPE

GRUPO MANILLAR

**06A**

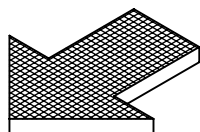
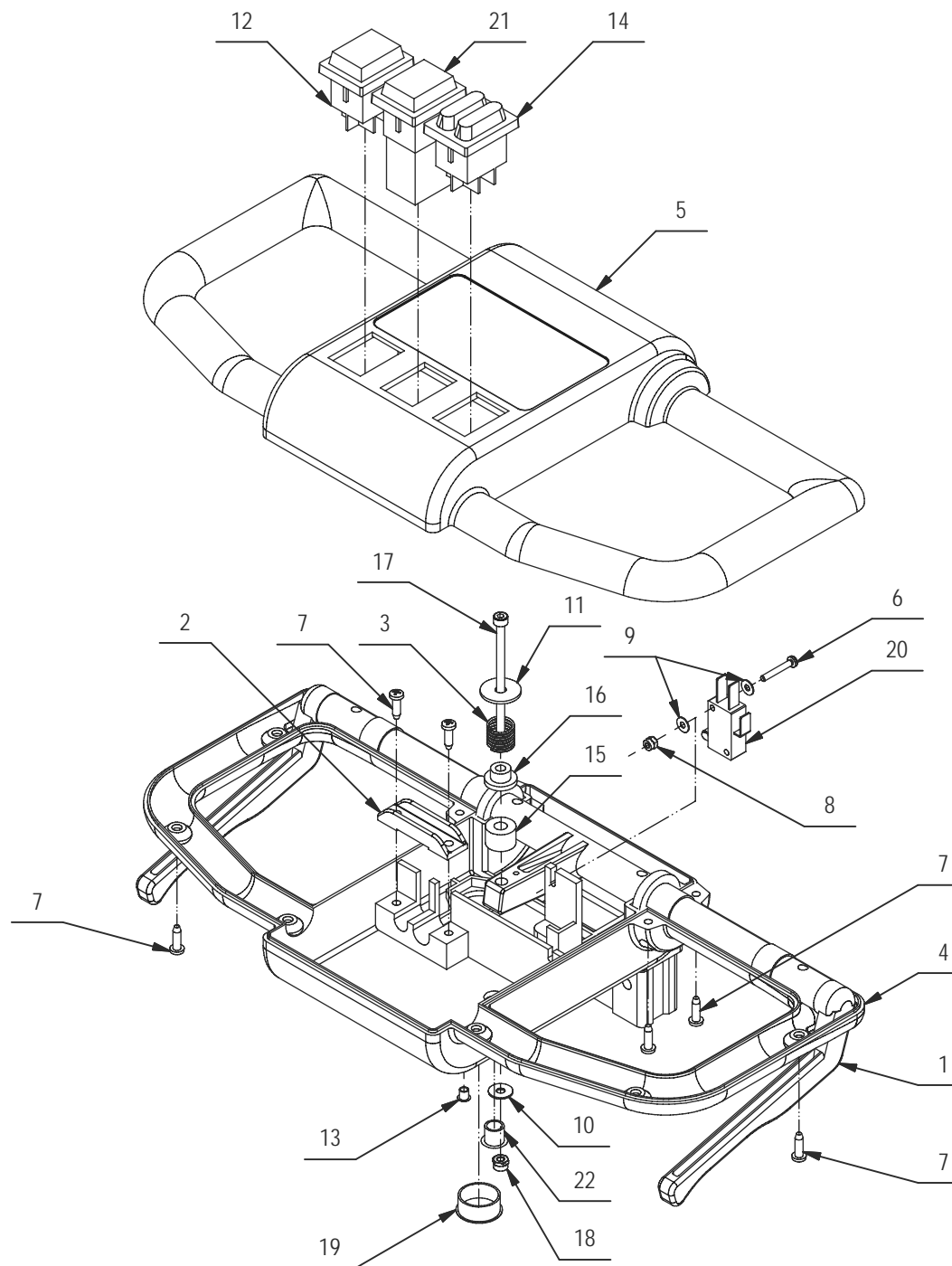

# GRUPPO MANUBRIO VISPA

# 06A

POS.	CODICE	QTÀ	DESCRIZIONE	DWENOMINATION	DESCRIPTION	BENENNUNG	DESCRIPCION
1	400449	1	MANETTA	LEVER	MANETTE	HEBEL	PALANCA
2	400738	1	PIASTRA FISSA CAVI	CABLE FASTENER	FIXAGE DE CABLE	KABELBEFESTIGUNG	BRIDA CABLE
3	408109	1	MOLLA COMPRESSIONE 13,5X36X1	SPRING	RESSORT	FEDER	RESORTE
4	408174	1	CORPO MANUBRIO	HANDLE BAR BODY	CORPS DE TIMON	FÜHRUNGSHOLMKÖRPER	CUERPO MANILLAR
5	408175	1	COPERCHIO MANUBRIO	HANDLE BAR COVER	COUVERCLE DE TIMON	DECKEL FÜHRUNGSHOLM	TAPA MANILLAR
6	408834	1	VITE M3X20 TCTC UNI 7687 ZINC	SCREW	VIS	SCHRAUBE	TORNILLO
7	408871	12	VITE D.3.9x13 AUTOF. NICH UNI 6954	SCREW	VIS	SCHRAUBE	TORNILLO
8	409077	1	DADO M3x4,5 AUTOBL. UNI 7474 ZINC	LOCK NUT	ECROU AUTOFREINES	SICHERUNGSMUTTER	TUERCA AUTOBLOCANTE
9	409139	2	ROSETTA 3x8x1 UNI 6593 ZINC	WASHER	RONDELLE	UNTERLAGSCHEIBE	ARANDELA
10	409144	1	ROSETTA 4x12x1,5 UNI 6593 ZINC	WASHER	RONDELLE	UNTERLAGSCHEIBE	ARANDELA
11	409153	1	ROSETTA 5X20X1,5 UNI 6593 ZINC	WASHER	RONDELLE	UNTERLAGSCHEIBE	ARANDELA
12	409483	1	INT. BIP. LUM. VERDE 24V PROT.	SWITCH	INTERRUPTEUR	SCHALTER	INTERRUPTOR
13	409827	1	TAPPO A SCATTO D 4,5	PLUG	BOUCHON	DECKEL	ASIENTO
14	412610	1	INTERRUT.DOPPIO VERDE 24V	GREEN DUOBLE SWITCH 24 V	VERT DOUBLE INTERRUPTEUR 24V	GRUEN DOPPEL SCHALTE 24 V	DOBLE INTERRUPTOR VERDE 24V
15	414688	1	DISTANZIALE D=15 d=6.5 S=10 PVC	SPACER	ENTRETOISE	DISTANZHÜLSE	DISTANCIADOR
16	414707	1	BOCCOLA D=16-10 d=5 S=8 OT58	BUSHING	BAGUE	BUCHSE	CASQUILLO
17	415753	1	VITE M4X65 TCEI UNI 5931 (8.8)	SCREW	VIS	SCHRAUBE	TORNILLO
18	415898	1	DADO M4 AUTOBL UNI7474	LOCK NUT	ECROU AUTOBLOQUANT	STOPMUTTER	TUERCA AUTOBLOCANTE
19	416316	1	TAPPO COPRIFORO D.20	COVER	COUVERCLE	DECKEL	CUBREAGUJERO
20	421748	1	MICROINT. HONEYWELL VSC010CB3D 3A	MICROSWITCH	MICROINTERRUPTEUR	MIKROSCHALTER	MICROINTERRUPTOR
21	421806	1	SC. LIV. BAT.12-24-36 PB-GEL RQ1T	CHECK CARD BATTERIES	PLAQUE CONTROLE BATTERIES	KONTROLLEL. BATTERIEN	FICHA CONTROL BATERIAS
22	422110	1	TAPPO A SCATTO D=10	CAP	CAPUCHON	KAPPE	TAPON

**GRUPPO IMPIANTO ELETTRICO VISPA**

ELECTRONICAL CONTROL ASSEMBLY

ENSEMBLE COMMANDE ELECTR.

ELEKTRONISCHE ANLAGE

GRUPO CONTROLES ELECTR.

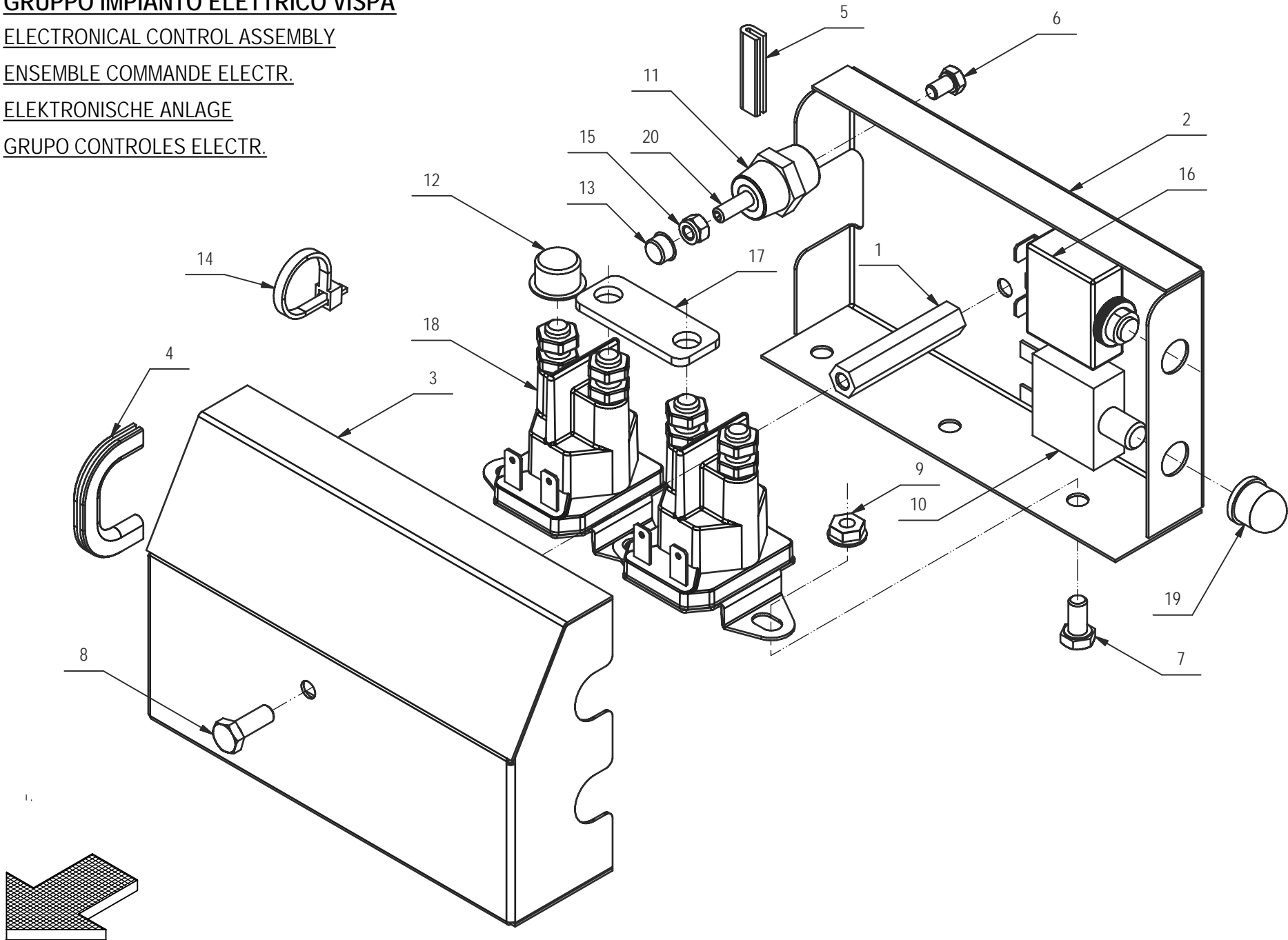

## GRUPPO IMPIANTO ELETTRICO VISPA

07

POS.	CODICE	QTÀ	DESCRIZIONE	DENOMINATION	DESCRIPTION	BENENNUNG	DESCRIPCION
1	212366	1	DISTANZIALE IMPIANTO ELETTRICO	SPACER	ENTRETOISE	DISTANZHÜLSE	DISTANCIADOR
2	213124	1	PANNELLO IMPIANTO ELETTRICO	PANEL	PANNEAU	BLECH	PANEL
3	213125	1	COPERCHIO IMPIANTO ELETTRICO	COVER	COUVERCLE	DECKEL	TAPA
4	213321	1	PROFILO GOMMA A -U- 8,5X6 L=70	PROFILE	PROFIL	PROFIL	PERFIL
5	213322	1	PROFILO GOMMA A -U- 8,5X6 L=30	PROFILE	PROFIL	PROFIL	PERFIL
6	407643	1	VITE M5X8 TE UNI 5739 ZINC	SCREW	VIS	SCHRAUBE	TORNILLO
7	407659	3	VITE M6X12 TE UNI 5739 DIN 933 8.8 ZINC	SCREW	VIS	SCHRAUBE	TORNILLO
8	407663	1	VITE M6x16 TE UNI 5739 ZINC	SCREW	VIS	SCHRAUBE	TORNILLO
9	409125	3	DADO M6 SERPRESS	NUT	ECROU	MUTTER	TUERCA
10	409514	1	DISGIUNTORE TERMICO 20A	CONTACT BREAKER	DISJONCTEUR	AUFTRENNER	DISYUNTOR
11	409767	1	ISOLATORE M5x25 FF	INSULATOR	ISOLATEUR	ISOLATOR	AISLADOR
12	409832	4	TAPPO SALVAFILETTO DIAM.14.5	CAP	CAPUCHON	KAPPE	TAPON
13	409846	1	TAPPO A SCATTO D 8,5	PLUG	BOUCHON	DECKEL	ASIENTO
14	410275	15	FASCETTA PLASTICA 3,6x140	CLAMP	COLLIER	BRIDE	ABRAZADERA
15	415899	1	DADO M5 AUTOBL. BASSO UNI 7474	LOCK NUT	ECROU AUTOBLOQUANT	STOPMUTTER	TUERCA AUTOBLOCANTE
16	415997	1	DISGIUNTORE DI SICUREZZA 30A	CONTACT BREAKER	DISJONCTEUR SECURITE	AUFTRENNER	INTERRUPTOR SEGURIDAD
17	421575	1	PONTE TELERUTTORE	BRIDGE	PONTAGE	VERBINDUNGSBRÜCKE	PUENTE
18	421587	2	TELERUTTORE ITC 12V CO - 80A	REMOTE CONTROL SWITCH	TELERUPTEUR	SCHÜTZ	TELERRUPTOR
19	422000	1	CAPPUCCIO DISGIUNTORE SERIE AXDISTR	CAP	CAPUCHON	KAPPE	TAPON
20	422121	1	GRANO M5x20 UNI5929 (A COPPA)	DOWEL	VIS CYLINDRIQUE	MADENSCHRAUBE	TORNILLO

# ACCESSORI VISPA

ACCESSORIES

ACCESORIOS

ACCESSOIRES

ZUBEHORTEILE

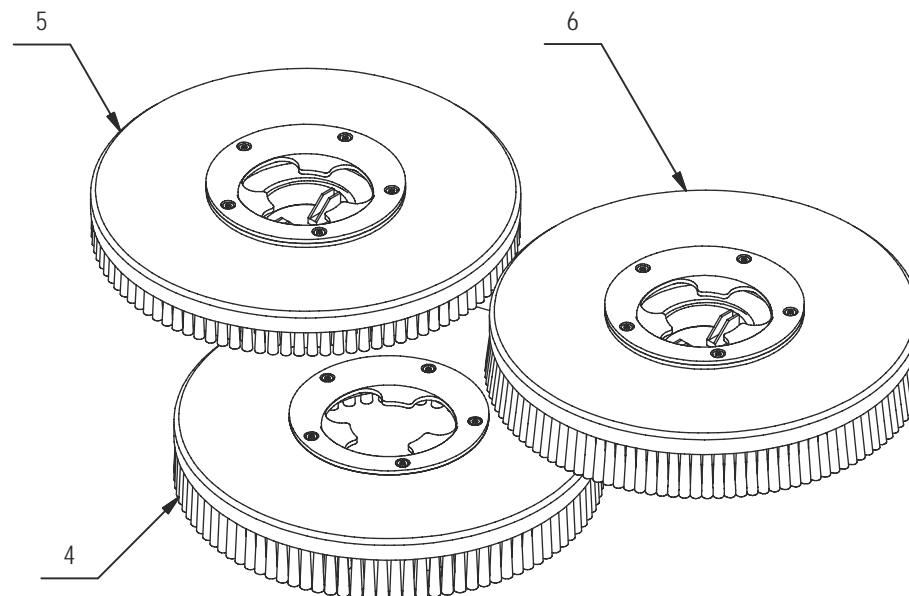
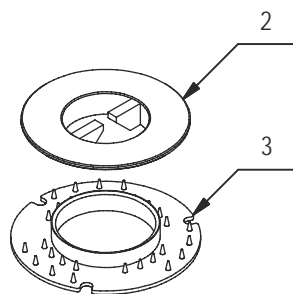
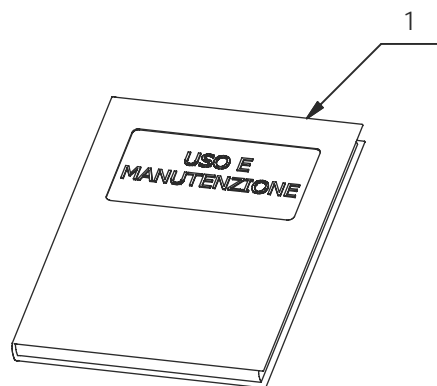

1.

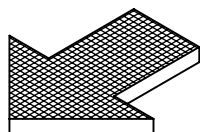

**ACCESSORI VISPA****08**

POS.	CODICE	QTÀ	DESCRIZIONE	DENOMINATION	DESCRIPTION	BENENNUNG	DESCRIPCION
1	422201	1	USO E MANUTENZIONE - GENERALE	USE AND MAINTENANCE	EMPLOI ET ENTRETIEN	BEDIENUNG UND WARTUNGS	USO Y MANTENIMIENTO
2	410575	1	CENTER LOCK BASSO A VITE VERDE	CENTER LOCK SCREW LOW	CENTER LOCK A VIS BAS	CENTER LOCK SCHRAUBE	CENTER LOCK TORNILLO BAJO
3	410576	1	CENTER LOCK ALTO A VITE VERDE	CENTER LOCK SCREW HIGH	CENTER LOCK A VIS HAUT	CENTER LOCK SCHRAUBE	CENTER LOCK TORNILLO ALTO
4	421701	1	SPAZZOLA PPL06 D=335 14" WIRBEL	BRUSH	BROSSE	BÜRSTE	CEPILLO
4b	421278	1	SPAZZOLA PPL03 D=335 14" WIRBEL	BRUSH	BROSSE	BÜRSTE	CEPILLO
4c	421492	1	SPAZZOLA PPL04 D=335 14" WIRBEL	BRUSH	BROSSE	BÜRSTE	CEPILLO
5	422001	1	DISCO TRASC. PUNZ. D.350 VISPA	BRUSH	BROSSE	BÜRSTE	CEPILLO
6	422213	1	TRASC. D.350 CON SETOLE LAT. VISPA	BRUSH	BROSSE	BÜRSTE	CEPILLO



---

Le descrizioni contenute nella presente pubblicazione non si intendono impegnative. La Ditta pertanto, si riserva il diritto di apportare in qualunque momento, le eventuali modifiche ad organi, dettagli, forniture di accessori, che essa ritiene convenienti per un miglioramento o per qualsiasi esigenza di carattere costruttivo o commerciale.

La riproduzione anche parziale dei testi e dei disegni, contenuti nel presente catalogo, è vietata ai sensi di legge.

---

The descriptions and illustrations contained in the present publication are understood to be non-binding. The Manufacturer thus reserves the rights to effect, at any time any such alterations to items, component parts and accessory supplies as it may deem necessary for the purposes of improvement or in order to meet any demand of constructional or commercial nature.

Reproduction of either text or drawings, in full or in part, other than with the prior written consent of Comac, is expressly forbidden.

---

Les descriptions et les illustrations contenues dans la présente publication n'engagent pas le constructeur. Le Fabriquant se réserve le droit de modifier à tout moment les organes, détails et fournitures d'accessoires nécessaires à une amélioration technique ou commerciale des machines.

La reproduction même partielle des textes et illustrations contenus dans ce catalogue est illégale, tout contrairement elle pourra être pénalement poursuivie.

---

Die in dieser Anleitung enthaltenen Beschreibungen und Abbildungen sind unverbindlich. Die Firma behält sich das Recht vor, eventuelle Änderungen an Elementen, Einzelteilen und Lieferungen von Zubehörteilen ohne Ankündigung vorzunehmen, welche sich im Hinblick auf konstruktive Verbesserungen ergeben.

Der Nachdruck der Texte und Zeichnungen, die in diesem Katalog enthalten sind, auch teilweise, ist laut Gesetz untersagt.

---

Las descripciones contenidas en esa publicación no son vinculantes. Por consiguiente la Empresa se reserva el derecho de modificar eventualmente en cualquier momento las piezas, los detalles y los suministros de piezas de repuesto, de la manera que considera útil para lograr mejoras o por cualquier exigencia de tipo constructivo o comercial.

La reproducción aún parcial de los textos y de los dibujos contenidos en este catálogo queda prohibida con arreglo a la ley.

---



